

# The Corporation of the Town of Bradford West Gwillimbury

## By-law 2026-021

A by-law to designate the Bond Head Heritage Conservation District and to adopt a Heritage Conservation District Plan regarding same.

---

WHEREAS subsection 41(1) of the *Ontario Heritage Act*, R.S.O. 1990, c.0.18 ("Act") authorizes the Council of a municipality to enact a by-law to designate the municipality or any defined area thereof as a heritage conservation district;

AND WHEREAS subsection 41.1 (1) of the Act authorizes the Council of a municipality to adopt a heritage conservation district plan for each district that is designated as a heritage conservation district by such by-law;

AND WHEREAS the Official Plan for the Town of Bradford West Gwillimbury contains policies relating to the establishment of heritage conservation districts;

AND WHEREAS Council for the Town of Bradford West Gwillimbury ("Council") intends to designate the area defined by this by-law as a heritage conservation district known as the Bond Head Heritage Conservation District ("Bond Head HCD");

AND WHEREAS, Council passed resolution 2025-235 on August 5, 2025 to endorse a proposed Heritage Conservation District boundary and Guidelines; and,

AND WHEREAS pursuant to subsection 41.1 (6) (a) and (b) of the Act, information relating to the proposed Village of Bond Head HCD plan, including a copy of the plan, has been made available to the public and a public meeting in respect of the Bond Head HCD Plan was held on October 14, 2025, with the appropriate notice of the public meeting given in accordance with the Act;

AND WHEREAS pursuant to subsection 41.1 (6)( c) of the Act, Council has consulted with its municipal heritage committee with respect to the Bond Head HCD;

NOW THEREFORE the Council of The Corporation of the Town of Bradford West Gwillimbury enacts as follows:

1. The area shown on Schedule "A" attached hereto and forming part of this bylaw is hereby designated as a heritage conservation district known as the Bond Head Heritage Conservation District.
2. The Plan set out in Schedule "B" attached hereto and forming part of this by-law is hereby adopted as the Heritage Conservation District Plan and Guidelines for the Bond Head Heritage Conservation District.

3. The Town Clerk is authorized to cause a copy of this by-law to be served upon each owner of property located in the Bond Head Heritage Conservation District and upon the Ontario Heritage Trust and to cause notice of this by-law to be published in a newspaper having general circulation in The Corporation of the Town of Bradford West Gwillimbury as required by the *Ontario Heritage Act*, R.S.O. 1990, c.0.18.
  
4. This by-law shall come into force in accordance with section 41 of the *Ontario Heritage Act*, R.S.O. 1990, either on the day following the last day of the prescribed appeal period or as otherwise provided by section 41(10) of the *Act*.

Enacted April 7, 2026.

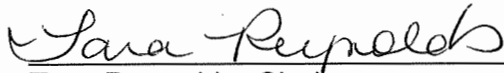

Tara Reynolds, Clerk



James Leduc, Mayor

# TOWN OF BRADFORD WEST GWILLIMBURY

## Schedule "A"

### By-law 2026-021

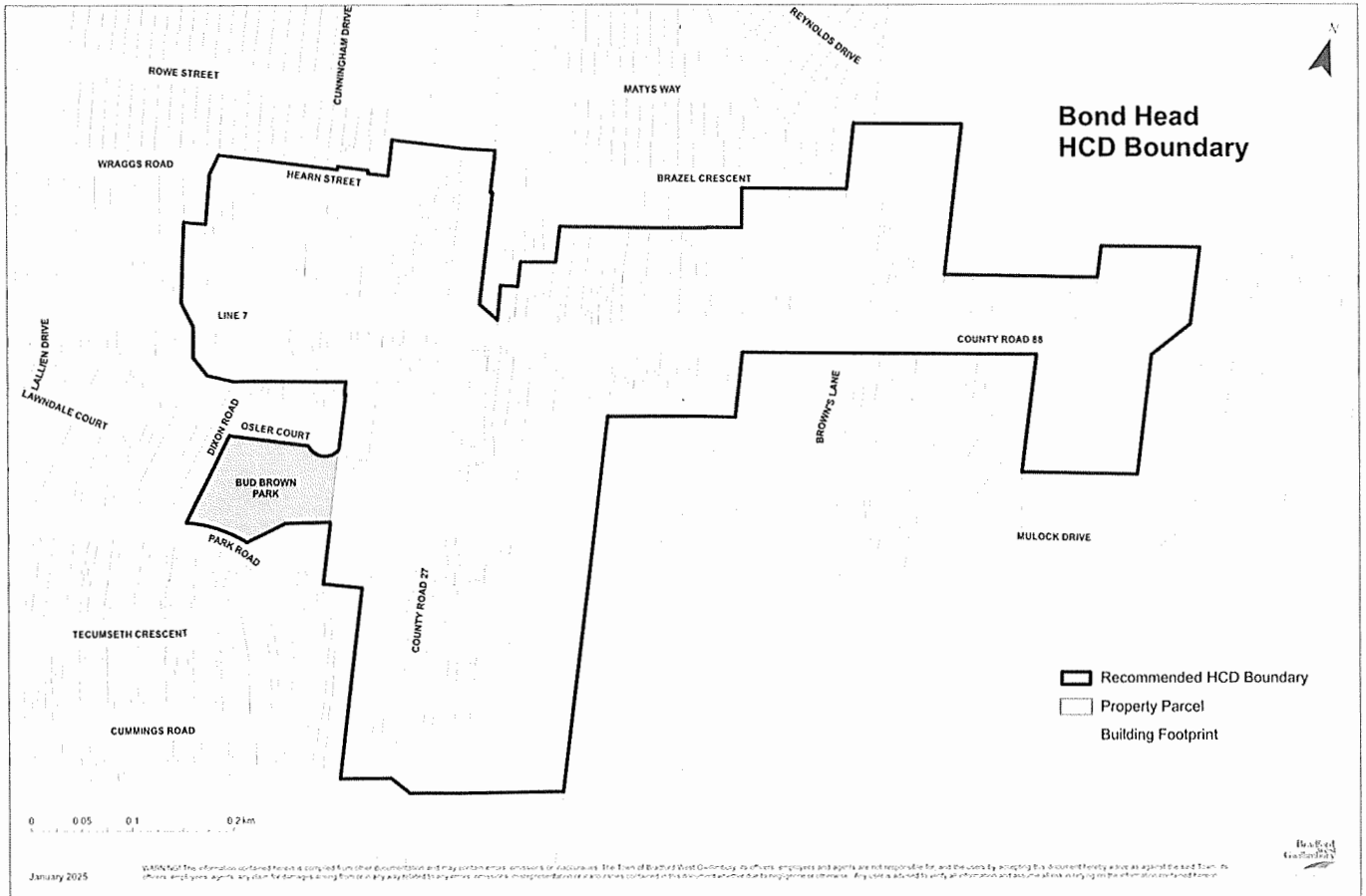

**TOWN OF BRADFORD WEST GWILLIMBURY**  
**Schedule "B"**  
**By-law 2026-021**

*(Heritage Conservation District Plan and Guidelines follows on next page)*

## Bond Head Heritage Conservation District Plan

Prepared for  
**The Town of Bradford West Gwillimbury**  
61 Holland Street East P.O. Box 160  
Bradford, ON L3Z 2A8  
Tel: (905) 775-5303 Fax: (905) 775-4472  
[www.townofbwg.com](http://www.townofbwg.com)

By:  
**Archaeological Research Associates Ltd.**  
50 Nebo Road, Unit 1  
Hamilton, ON L8W 2E3

**Dillon Consulting Limited**  
1155 North Service Road West Unit 14  
Oakville, Ontario, L6M 3E3  
[www.dillon.ca](http://www.dillon.ca)

and

**G. Douglas Vallee Limited**  
2 Talbot Street North  
Simcoe, Ontario N3Y 3W4  
[www.gdvallee.ca](http://www.gdvallee.ca)

HR-355-2021  
Project# 2021-0228  
Rev  
10/02/2026





**vallee**

*Consulting Engineers,  
Architects & Planners*

Where do I find Information on....:	Section of the HCD
...the HCD Boundary?	Section 2.2 Map 1: Bond Head HCD Boundary
,,, Property status? (Contributing or Supporting)	Table 1: Property Status in the District
....The Statement of Contribution for a property in the Boundary?	Appendix A: District Properties – Statement of Contribution
....Policies associated with Contributing Buildings?	Section 6.0, specifically Section 6.2
....Policies associated with Supporting Buildings?	Section 6.0, specifically Section 6.3
.... the heritage permit process?	Section 9.1



## TABLE OF CONTENTS

<b>1.0</b>	<b>INTRODUCTION</b>	<b>1</b>
1.1	Bond Head HCD Background	1
1.2	What is a Heritage Conservation District?	1
1.3	Ontario Regulation Criteria Met	1
1.4	How to use this Plan	2
1.4.1	Overall Intent of the District Plan	2
1.4.2	Implications of the District Plan	2
1.5	Community Consultation	3
<b>2.0</b>	<b>HERITAGE VALUE OF THE DISTRICT</b>	<b>4</b>
2.1	District Description	4
2.2	District Boundary	4
2.3	Statement of Cultural Heritage Value or Interest	6
2.4	Description of Cultural Heritage Attributes	7
<b>3.0</b>	<b>OBJECTIVES OF THE HCD</b>	<b>12</b>
3.1	General	12
3.2	Buildings and Properties	13
3.3	Streetscape, Public Realm, and Land-use	13
3.4	Implementation Process and Community Support	13
<b>4.0</b>	<b>MUNICIPAL POLICY FRAMEWORK</b>	<b>15</b>
4.1	Town of Bradford West Gwillimbury Official Plan (2021)	15
4.2	Town of Bradford West Gwillimbury Zoning By-Law	15
4.3	Site Plan Control	15
4.4	Demolition Control	15
4.5	Property Standard By-Law	16
<b>5.0</b>	<b>PROPERTY STATUS</b>	<b>17</b>
5.1	Part IV – Individual Property Designation Status	17
5.2	Part V – Status Within the District	17
5.3	District Property Status	18
5.3.1	Property Class: Contributing and Supporting	18
<b>6.0</b>	<b>DISTRICT POLICIES</b>	<b>21</b>
6.1	Development Patterns	21
6.2	Policies for Contributing Properties	21
6.2.1	Alterations and Additions to Contributing Buildings	21
6.2.2	Demolition	22
6.3	Policies for Supporting Properties	23
6.3.1	Alterations and Additions	23
6.3.2	Demolition	23
6.4	New Development	23
6.5	Streetscape and Public Realm	24
6.6	Implementation	24

6.7	Part IV Designations	25
6.8	Adjacent Property	25
<b>7.0</b>	<b>DISTRICT GUIDELINES – EXPLAINED</b>	<b>26</b>
7.1	Purpose and Organization	26
7.2	Guidelines Background	28
7.2.1	Urban Design Guidelines	28
7.3	Guideline Principles	28
<b>8.0</b>	<b>BOND HEAD HERITAGE DISTRICT GUIDELINES</b>	<b>30</b>
8.1	Alterations on Contributing Residential and Non-Residential Buildings	30
8.1.1	Roofs, Parapets and Chimneys	30
8.1.2	Exterior Walls	33
8.1.3	Windows	35
8.1.4	Entrances and Doors	37
8.1.5	Porches, Porticoes, Verandahs and Balconies	39
8.1.6	Foundations	41
8.2	Additional Guidelines for Contributing Non-Residential Buildings	42
8.2.1	Storefronts and Entrances	42
8.2.2	Signage, Lighting and Awnings	43
8.3	Additions to All Buildings	44
8.3.2	General Guidelines	44
8.3.3	Scale and Massing	44
8.3.4	Location and Orientation	45
8.3.5	Materials	46
8.4	Secondary Structures on All Properties	47
8.5	New Construction	48
8.5.1	General Guidelines	48
8.5.2	Scale and Massing	49
8.5.3	Building Location and Orientation	50
8.5.4	Materials	51
8.6	Demolition	51
8.6.1	Full and Partial Demolition of Contributing Properties	51
8.6.2	Full and Partial Demolition of Supporting Properties	52
8.7	Accessibility	52
8.8	Mechanical/Electrical and Utilities	53
8.9	Site Design/Landscaping	53
8.9.1	Trees and Landscaping/Tree Canopy	53
8.9.2	Landscape Filters, Fencing and Screening	54
8.9.3	Driveways, Laneways and Walkways	55
8.9.4	Parking and Access	55
8.10	Lot Severance and Assembly	56
8.11	General Maintenance	57
8.12	Public Realm	58

8.12.1	Building Design and Interface	58
8.12.2	Streetscapes	58
8.12.2.1	Sidewalks	58
8.12.2.2	Parking and Access	59
8.12.2.3	Street Furniture	59
8.12.2.4	Lighting	60
8.12.2.5	Gateways and Signage	60
8.12.2.6	Trees and Plantings	61
8.12.3	Parks and Open Spaces	62
<b>9.0</b>	<b>IMPLEMENTATION OF THE HCD PLAN</b>	<b>63</b>
9.1	Heritage Permit Process	63
9.2	Integration of the District Plan	71
9.3	Grants and Incentives	71
<b>10.0</b>	<b>GLOSSARY AND TERMS</b>	<b>73</b>
<b>11.0</b>	<b>BIBLIOGRAPHY AND SOURCES</b>	<b>77</b>

#### LIST OF APPENDICES

Appendix A: District Properties – Statement of Contribution	79
Appendix B: Policy Review and Implementation	79
Appendix C: Consultation Summary	79

#### LIST OF MAPS

Map 1: Bond Head HCD Boundary	5
Map 2: Map of Significant Viewscapes	11
Map 3: Property Status	20

#### LIST OF TABLES

Table 1: Property Status in the District	19
Table 2: Heritage Permit Requirements- Contributing Buildings	65
Table 3: Heritage Permit Requirements- Supporting Buildings	67

#### LIST OF FIGURES

Figure 1: Heritage Permit Review Process	70
--	----

## GLOSSARY OF ABBREVIATIONS

ARA – Archaeological Research Associates Ltd.  
BHR – Built Heritage Resource  
BWG – Bradford West Gwillimbury  
CHVI – Cultural Heritage Value or Interest  
CHL – Cultural Heritage Landscape  
CHRIA – Cultural Heritage Resource Impact Assessment  
HCD – Heritage Conservation District  
HSMBC – Historic Sites and Monuments Board of Canada  
MCM – Ministry of Multiculturalism and Citizenship  
OHA – Ontario Heritage Act  
OHT – Ontario Heritage Trust  
O. Reg. – Ontario Regulation  
OP – Official Plan  
PPS – Provincial Policy Statement  
UDG – Urban Design Guidelines

## PERSONNEL

### ARA

**Director - Heritage Operations:** K. Jonas Galvin, MA, RPP, MCIP, CAHP

**Project Manager:** J. McDermid, BA, CAHP

**Consultation Manager:** A. Barnes MA, CAHP

**Field Surveys:** K. Jonas Galvin, J. McDermid

**Historical Research:** S. Clarke, BA, CAHP

**Cartographers:** A. Bailey (GIS), K. Brightwell (GIS)

**Technical Writers:** A. Bousfield-Bastedo B.A., Dip. Heritage Conservation, V. Cafik, BA, CAHP,  
K. Jonas Galvin, V. Nagy, C. Williamson MA

### Dillon Consulting Ltd.

**Policy Coordinator:** M. Kosterman, RPP, MCIP, LEED AP

**Policy:** T. O'Neill MA.

**Consultation Support:** F. Oloruntoba MA, PMP

### G. Douglas Vallee Limited

**Architect:** M. Stickl Stewart BAS, M. Arch, OAA, MRAIC

## 1.0 INTRODUCTION

### 1.1 Bond Head HCD Background

The Bond Head Heritage Conservation District (henceforth “the District”) is the result of local community and municipal interest in the conservation of Bond Head’s cultural heritage resources. Since 2007, the Town of Bradford West Gwillimbury (“the Town”) has explored the idea of the creation of a Heritage Conservation District (HCD) for Bond Head. Between 2017 and 2019, Archaeological Research Associates (“ARA”) completed the District Study. The District Study resulted in the development of a boundary and established the cultural heritage value or interest (CHVI) and the heritage attributes.

#### What is a Heritage Attribute?

Heritage attributes in relation to real property, and to the buildings and structures on the real property, the attributes of the property, buildings and structures that contribute to their cultural heritage value or interest. (PPS 2024).

### 1.2 What is a Heritage Conservation District?

An HCD, defined under Part V of the *Ontario Heritage Act*, is a geographical area within a municipality protected under a local by-law to ensure the conservation of its existing heritage character. The focus of this type of designation is on the prevailing character of an area, particularly its contextual attributes – such as the variety of buildings and how they interrelate, the physical attributes including trees, landscapes, building setbacks, roads, street furniture and lighting. HCDs vary in size, and most are defined by a number of properties that form a character area. HCDs often incorporate natural heritage features like open green space, trees, parkland and waterways. HCDs form an integral part of a community or region’s cultural heritage and contribute to an understanding and appreciation of the area’s cultural identity.

### 1.3 Ontario Regulation Criteria Met

Ontario Regulation 569/22 sets out the criteria for designation of an HCD. Specifically, 3. (2).1 notes that 25 percent or more of the properties within the boundaries must meet two or more of the criteria. The Bond Head Heritage Conservation District meets this threshold.

Within the HCD there are 75 properties and 45 (60%) properties that meet at least two criteria under O. Reg. 569/22 therefore the Bond Head HCD meets the criteria for designation under the *Ontario Heritage Act*.

## 1.4 How to use this Plan

### 1.4.1 Overall Intent of the District Plan

The purpose of the District Plan is to provide clear and concise objectives, policies, and guidelines to protect, conserve, or enhance the Bond Head's heritage and character. An HCD designation is not intended to prohibit any changes required by contemporary needs. The purpose is to guide those changes to ensure that they contribute to the heritage character of the District.

The primary focus of heritage conservation districts is on the streetscape, visible elements from the public realm including buildings, landscapes, and open spaces.

Heritage Districts are concerned with the public facing elements and **do not consider the interior of buildings.**

### 1.4.2 Implications of the District Plan

HCDs focus on the conservation of the overall district boundary and provide the information and planning tools that allow for the conservation and enhancement of the unique area. A HCD is intended to help protect what exists and manage changes in a way which does not detract from the District area. It is not intended to keep an area 'frozen' in time or require the restoration to a specific time period. It is intended to allow for responsible meaningful changes which are compatible with the character and value of the area.

Policies and guidelines are developed to provide direction and guidance on the types of alterations, additions, or new construction that will be considered appropriate and those which require additional planning consideration and study.

District Designation can offer the following benefits to property owners:

- Useful Information and guidance for property owners who are undertaking renovation, restoration and/or redevelopment;
- Potential municipal assistance and programming (i.e., grants, tax relief programs) for conservation efforts and improvements;
- Sympathetic land-use planning and management which considers the communities heritage assets (architecture, parks, open or green space, development patterns and history);
- Potential cultural tourism initiatives (historic walking tours, interpretive features signage) and new promotion; and
- Increased community stability.

Heritage permits, by way of the heritage permitting process, are required for major alterations (i.e. additions, demolitions, relocations, or new construction). The appropriateness of the proposed changes is assessed using the policies and guidelines contained in this District Plan. Similarly, policies and guidelines identify where a permit may not be required. (i.e. undertaking minor alterations, additions/ renovations at the rear of buildings.

### **District Policies**

The heritage policies and management tools are not intended to be overly restrictive, cumbersome or an imposition to property owners or their rights. They are intended to provide the opportunity and framework to maintain and enhance the villages' most unique and attractive features for the overall benefit of the community and future generations.

### **District Guidelines**

The guidelines are intended to provide useful information should a property owner decide to make modifications and/or undertake renovations to building façades that are visible from the public realm. In instances where it has been determined that a change will not negatively impact the heritage character of the District, guidelines are provided to assist with maintenance and repair, landscape areas, open spaces or public realm features.

The policies and guidelines have been developed with community input while balancing heritage best practices and the appropriate level of protection.

## **1.5 Community Consultation**

The *Ontario Heritage Act (OHA)* legislatively requires at least one public consultation be carried out as part of the development of the District. For this project, three public consultation events were carried out during the development of the District Study and another three consultation events were carried out throughout the development of the District Plan.

A robust community consultation strategy was developed to ensure that the information collected through the development of the District Plan was reflective of the needs and opinions of the community to which it affects. The consultation approach provided multiple methods of engagement and the information gathered aided in the development of the District objectives, policies and guidelines and implementation approaches. The consultation included two levels of engagement: a public consultation process and the formation of a focus group. The public consultation events took place virtually and in person. See Appendix C for full consultation summary.

Additional comments were received during the statutory public meeting October 14, 2025. Relevant comments were considered and HCD Plan was revised accordingly.

## **2.0 HERITAGE VALUE OF THE DISTRICT**

### **2.1 District Description**

As established through the District Study, the District includes 75 properties located within an irregularly shaped boundary that centres on, and radiates from, the crossroads of County Road 88/Line 7 and County Road 27 (see Map 1). The central crossroads represents the commercial core of the village comprised of mixed land uses including residential, commercial, institutional, industrial, and recreational. The District boundary extend to approximately Hearn Street/Dixon Road in the west, St. Catherine of Alexandria Byzantine Church (west side only) on County Road 27 in the north, Mulock Drive in the east, and to the last residential properties on County Road 27 in the south.

### **2.2 District Boundary**

The primary focus and intent behind the District Plan is to conserve the streetscape and public experience of the character of the Bond Head. Only properties with lot frontage onto County Road 88, County Road 27 and Line 7, or with frontages otherwise visible from the street, contribute to that character. The final District boundary was determined through historic study and public consultation conducted as part of the HCD Study.

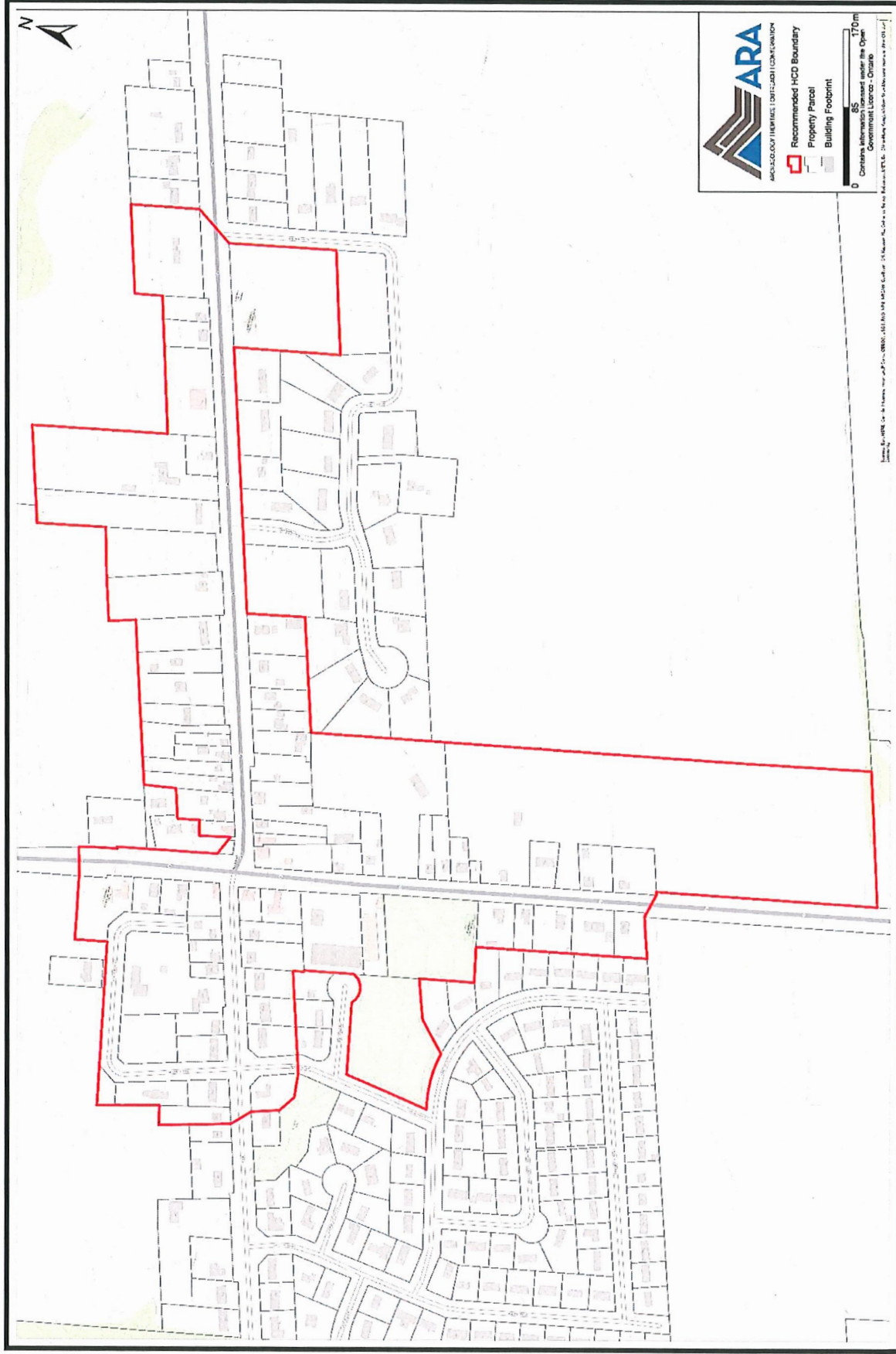

**Map 1: Bond Head HCD Boundary**  
(Produced under licence using ArcGIS® software by Esri, © Esri)

## 2.3 Statement of Cultural Heritage Value or Interest

### DESIGN/PHYSICAL VALUE

**The proposed Bond Head Heritage Conservation District has design/physical value as a representative example of a largely intact historic village community dating from the mid-19<sup>th</sup> century. The proposed HCD reflects a variety of architectural styles that contribute to a varied, yet cohesive streetscape.** The variety of architecture styles and materials found in Bond Head are representative of an intact historic crossroads village that developed in the mid-to-late 19<sup>th</sup> century. The economic and cultural conditions at Bond Head that both prompted and slowed development throughout its history are reflected in the extant and evolving nature of the land uses as well as the variety of architectural forms, which primarily include Georgian, Regency, Gothic Revival, Edwardian and vernacular expressions. Individually, these structures are representative examples of their architectural styles; collectively, they create a robust and varied streetscape of non-residential and residential buildings. The character of the village's core is further improved by the presence of designed green spaces, such as Bud Brown Memorial Park and Audrey Wychopen Memorial Park.

The prevalence of brick used as a building material post-1892 is visually and historically linked to its surroundings as a testament to the fires that occurred in 1880 and 1892 at the village crossroads. These fires destroyed a significant portion of the heart of the commercial area on the north and south sides of County Road 88 and industrial properties on the south side of Line 7. Following these devastating fires, many of the lost commercial and residential buildings were reconstructed, representing a visually notably building era in Bond Head today. The reconstructed buildings took advantage of brick as an added measure of fire safety over the once more common frame construction.

### HISTORICAL/ASSOCIATIVE VALUE

**The proposed Bond Head Heritage Conservation District possesses cultural heritage value or interest due to its direct association with notable historically significant individuals such as Sir Francis Bond Head, Rev. Featherstone Lake Osler, Sir William Osler and Dr. Thomas Homan Mulock, who have all been memorialized by having the village or village streets named in their honour.** Originally known as Wraggs Corners after retired military pensioner and early settler Major Wraggs, the settlement was renamed Bond Head in 1837 in commemoration of Sir Francis Bond Head, Lieutenant Governor of Upper Canada in 1835. Rev. Featherstone Lake Osler, the first permanent Anglican priest of the parish, arrived in 1837 from England and from a sea-faring life as a naval officer. He is associated with the former Trinity Anglican Church, which was moved to its current location on Hearn Street in 1885 and today functions as the St. Catherine of Alexandria Catholic Church. Sir William Osler, son of Rev. Featherstone Osler, was a physician and resident of Bond Head and is considered the "Father of Modern Medicine." His birthplace is commemorated with a cairn on the original location of the Trinity Anglican Church, east of Bond Head, which was erected by the Toronto Medical Historical Club in 1961 and constructed with stones from a barn on the property. Osler was not the first physician and educator at Bond Head; however, it was Dr. Thomas Homan Mulock who practiced medicine for some of the earliest village inhabitants. His son, Sir William Mulock, became Chief Justice of the Exchequer Division as well as a lawyer, businessman, farmer, politician, judge and philanthropist. The significance of Sir William Mulock and Sir William Osler's contributions to the Town of Bradford West Gwillimbury and the province have been recognized with Ontario Heritage Trust plaques erected in the village core.

## CONTEXTUAL VALUE

**The proposed Bond Head Heritage Conservation District has cultural heritage value or interest due to its physical, functional and historical links to its surroundings.** Historically, Bond Head was known as the “Half Way Stopping Place.” The railway bypassed the village, and as such, it functioned as a half-way point for travellers heading eastward from Tecumseth and West Gwillimbury Townships to Holland Landing along what is now County Road 88. Along this route, log and frame residences were interspersed with commercial operations and hotels offered weary travellers a place to rest. Various commercial operations were established to serve this transient population. Blacksmiths helped with shoeing travellers’ horses and general jobbing, while the post office, established in 1837, secured Bond Head as an important stop in Simcoe County. As such, the village is considered one of the earliest settlements in the Township of West Gwillimbury. The commercial core, notably the two remaining former hotel structures, provide visual links to the village’s past economic significance, both locally and within the county, while the residential structures, specifically the early homes, memorialize the initial agricultural foundations of the region and the perseverance of early pioneers. The combination of these landscape elements unite to reveal Bond Head’s significant and storied past and their relationships and contribution to the streetscape define the unique character of this early village.

The village context is characterized by a rolling topography that affords views of the village crossroads and surrounding landscape. Many of the historic properties feature mature vegetation and a tree canopy provides cover over the south extent of County Road 27 at the village limits. Bond Head’s street network is primarily composed of a rural cross-section, with the exception of an urban cross-section radiating from the village crossroads, and a variety of setbacks ranging from the placement of commercial structures at the sidewalk edge to residential structures obscured by deep, densely treed yards.

**The proposed Bond Head Heritage Conservation District has cultural heritage value or interest because it is recognized as a landmark.** Aside from individual landmark buildings within the proposed HCD, Bond Head itself is a landmark. Significant views include the village approach from the east that terminates on the iconic view to the Brazill House Hotel in the heart of the commercial core, as well as views from the south and west of the tall steeple rising from the St. Catherine of Alexandria Byzantine Church.

### 2.4 Description of Cultural Heritage Attributes

#### General

- Collection of structures dating from the mid-19<sup>th</sup> to early-20<sup>th</sup> century representing different architectural styles and materials expressed in rural Ontario villages during this era;
- Collection of residential structures located along the crossroads of the village’s commercial core, primarily constructed of red brick;
- Commercial properties located at the village crossroads, including the two remaining historic hotel buildings;
- Variety of setbacks, shifting from minimal in the village core to more significant setbacks from the road nearer the village limits;
- Public open spaces and small building footprints on large lots located in the east and south portion of the district providing significant amounts of space between buildings;
- Low-density scale and massing of structures exclusively ranging from one to two-storey building heights;

Landmark properties:

- Brazill House Hotel (2930 County Road 27);
- Brazel-Chambers House (By-law 1983-65) (4370 Line 7);
- Bond Head Memorial Community Hall (2892 County Road 27);
- Bud Brown Memorial Park and stone gates with plaques (7 Dixon Road);
- St. Catherine of Alexandria Byzantine Church (56 Hearn Street);
- Bond Head United Church and Bond Head Presbyterian Cemetery (4221 County Road 88);
- Former Bond Head U.S.S. #5 (4208 County Road 88); and
- Quaint House (4240 County Road 88).



4370 Line 7



2892 County Road 27



4221 County Road 88



56 Hearn Street



4240 County Road 88



2930 County Road 27

**Audrey Wychopen Memorial Park:**

- Old Plank Road Plaque;
- Bench/seating;
- Flagpole;
- Gardens/planters;
- Manicured lawns; and
- Mature trees.



**Audrey Wychopen Memorial Park**

**Bud Brown Memorial Park:**

- Memorial stone gateway with plaques;
- Ontario Heritage Trust plaques (2);
- Basketball courts;
- Baseball diamond;
- Soccer fields;
- Open green space; and
- Mature trees.



**Bud Brown Memorial Park:**

Views including:

- Terminating view to the Brazill House Hotel:
  - Iconic terminating long-view from the east extent of the village beginning at the former Bond Head U.S.S.#5 and United Church looking west down Country Road 88 to the terminus Brazill House Hotel (View 1)
  - Iconic terminating short-view from the east beginning where the historic properties began to have a narrower set back, looking west down Country Road 88 to the terminus Brazill House Hotel. (View 2)
- View from the south extent of the village looking north up County Road 27 to the St. Catherine of Alexandria Byzantine Church located on a rise at the north extent of the village (View 3);
- View to the southern boundary of the village on County Road 27 including the dense tree canopy and historic residential properties with limited setbacks (View 4)
- View to the Brazel-Chambers House from Line 7 looking north (View 5)
- Terminating view looking east down Hearn Avenue to St. Catherine of Alexandria Catholic Church, flanked by a row of mature trees to the south (View 6)



View 4 – View to Southern Boundary of Village on CR 27



View 2 – Terminating Short-View to Brazill House



View 1 – Terminating Long-View to Brazill House (Hotel)



View 6 – Terminating View East Down Hearn Ave

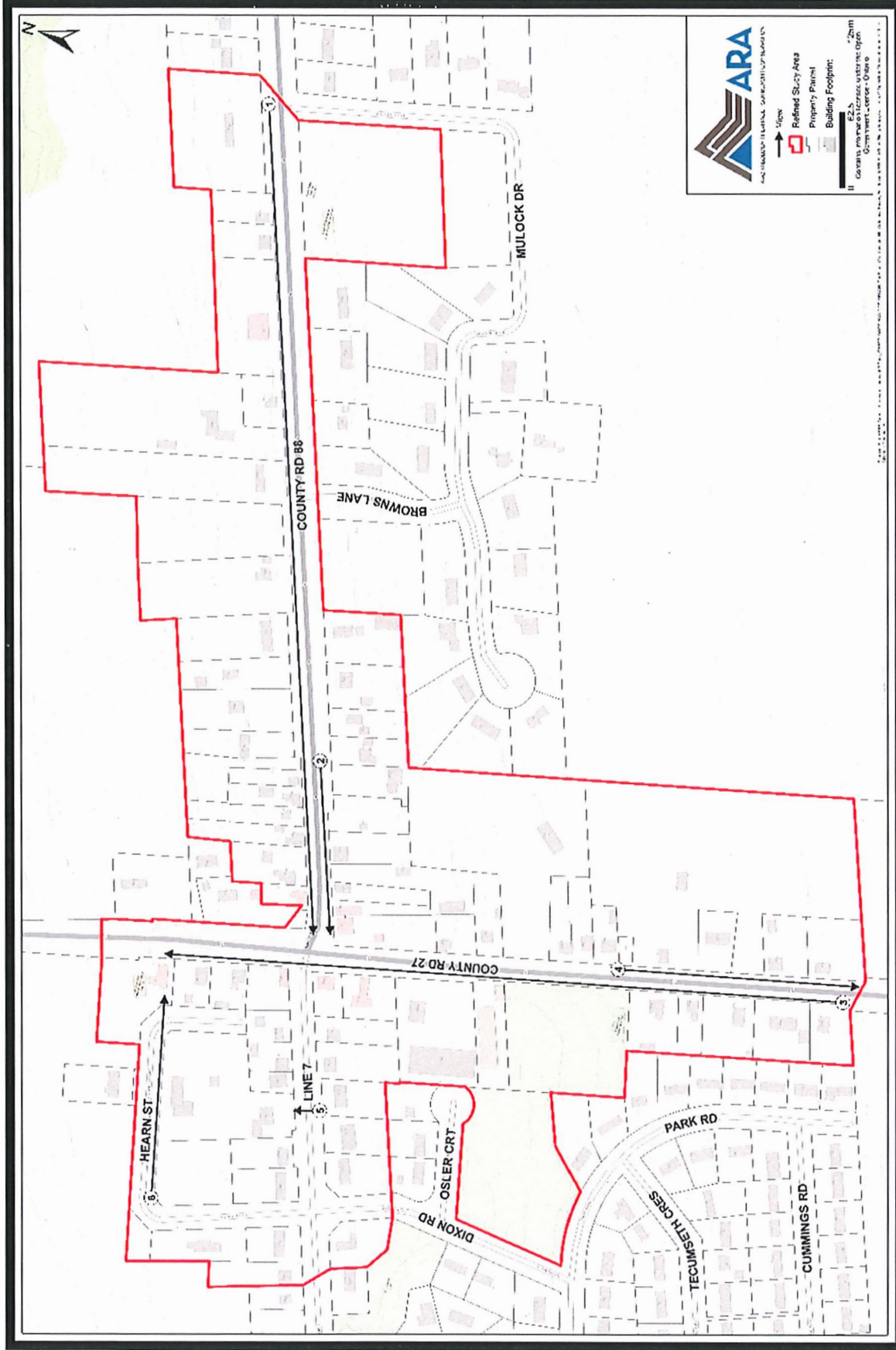

**Map 2: Map of Significant Viewscapes**  
 (Produced under licence using ArcGIS® software by Esri, © Esri)

### 3.0 OBJECTIVES OF THE HCD

The Objectives provides the framework for the protection and conservation of the District's unique heritage character and attributes over the long term and is fundamental to the conservation policies and associated guidelines. The Objectives reflect goals for the protection and management of the District. Any and all future changes in the District must be consistent with the Objectives of the District Plan.

The Objectives are best organized into four overarching themes: Protect, Maintain, Guide, and Community. The Objectives are outlined below.

The Objectives seek to ensure that:

- The heritage value and village character of the District is **protected**;
- The historic integrity of the district is visibly **maintained**
- The District Plan will **guide** and manage proposed changes in a way which supports and/or enhances the District character;
- The District Plan is a **community** tool to help achieve these objectives.

### 3.1 General

Acknowledge, appreciate, support, protect, and enhance the cultural heritage resources, (including buildings, views, landscapes, historical development pattern), for their value and contribution to Bond Head by:

- Conserving Bond Head's unique settlement and development patterns of the largely intact historic village dating from the mid-19th and early 20<sup>th</sup> century and the relatively cohesive streetscapes.
- Encouraging ongoing maintenance, retention, and adaptation of heritage buildings rather than the demolition and replacement of those buildings.
- Recognizing that streets, parks, trees, open spaces, monuments, street furniture, signs, whether public or privately owned contribute to the visual experience and heritage value of a community.
- Providing guidance and information for proposed changes so that the historic integrity of the District is maintained and where possible, enhanced.
- Providing residents and property owners with the necessary information about appropriate methods of maintenance and conservation through the guidelines so that appropriate building and repair activities can be undertaken.
- Promoting the retention and reuse of Contributing buildings to ensure that all reasonable and potential options for retention and reuse have been considered prior to considering demolition.
- Encouraging opportunities to revitalize the commercial core of the village while retaining the village character.

### 3.2 Buildings and Properties

Discourage unsympathetic alteration, relocation, or demolition of Contributing buildings and/or their heritage attributes and encourage opportunities for enhancement of supporting buildings or vacant lands by:

- Protecting and conserving the buildings, streetscapes, and parks, for their contribution to the District values as defined in the Statement of Cultural Heritage Value or Interest as well as their individual Statement of Contribution.
- Encouraging sensitive and sympathetic conservation or restoration practices that make modest and reversible changes, only when necessary, to Contributing properties.
- Strongly discouraging the demolition of Contributing properties and the removal or alteration of distinctive architectural details and heritage attributes;
- Permitting alterations and/or additions to Contributing buildings that do not diminish or detract from their individual heritage attributes as defined in their properties' Statements of Contribution.
- Encouraging any new development that employs high quality architecture and design which reinforces and enhances the District's character.
- Guiding new development and/or alterations in a way which allows for contemporary needs, while ensuring the design is compatible and in keeping with the character of village.
- Ensuring that adaptive reuse, infill development, or redevelopment is compatible with the heritage character of the village and the pedestrian scale of the District.
- Establishing policies and design guidelines to ensure that any new development and alterations to Contributing buildings are sensitive to the heritage attributes and details of the District.

### 3.3 Streetscape, Public Realm, and Land-use

Support, maintain, and enhance the visual integrity and contextual character of both the physical and natural elements of the District streetscape and public realms by:

- Maintaining the low-density of the one-to-three-storey visual appearance of the streetscape and District as a whole.
- Maintaining, and enhancing, where and when possible, the vegetation, greenery and park-like settings associated with Bud Brown Memorial Park and Audrey Wychopen Memorial Park.
- Maintaining existing tree canopy where and when possible and supporting the development of a replacement program to ensure successful tree succession.
- Maintaining, and where possible enhancing, the pedestrian experience through street furniture, lighting, signage, and connectivity within the District, including sidewalks and trails.
- Maintaining and enhancing high quality landscapes and public spaces.
- Establishing a review process which considers all potential impacts to the historic character and streetscape as a result of any proposed high density uses and/or change in land use.

### 3.4 Implementation Process and Community Support

Building community support through the promotion of the District and ensuring that the heritage permitting process is effective and user friendly by:

- Fostering community identity, pride and appreciation for the heritage value of the District and promoting the need to protect and conserve this character for future generations.
- Ensuring the heritage permit process and approvals is effective, efficient, streamlined and clearly understood by the community and property owners.
- Providing property owners with access to information, regarding funding, grants, or rebate programs that exist, are created, or should be considered.
- Encourage community participation and meaningful involvement in the review of development proposals and/or heritage applications in the District.

## 4.0 MUNICIPAL POLICY FRAMEWORK

The following section outlines the municipal documents which include provisions to control land-use and development within the District. A detailed policy framework review which has been used to inform the District Plan is provided in Appendix B.

### 4.1 Town of Bradford West Gwillimbury Official Plan (2021)

The 2021 *Official Plan* (OP) provides clear direction on the land-use decision and development with Bradford West Gwillimbury (BWG) addressing current and future planning needs. Specifically, the OP vision speaks to the importance of Bradford West Gwillimbury's history and protection of heritage (BWG OP 2021: Section 2.1). One of five main goals and objectives of the BWG OP 2021 is to "conserve and enhance natural and cultural resources" (BWG OP 2021, Section 2.2.4). The OP includes several sections which relate to the protection of cultural heritage resources. In the BWG OP 2021, Section 7 Implementing the Plan includes policies on Community Improvement Plans, (Section 7.1.5) Property Standards (Section 7.1.7), and Demolition Control (Section 7.1.8), which all address cultural resource conservation.

The Town of BWG's OP, including the Bond Head Secondary Plan, contains general policies in support of the conservation and enhancement of natural and cultural heritage resources (BWG OP, 2.2.4 & 3.8.1) in the municipality. To add further reinforcement in protecting heritage resources, Council is directed to use the relevant provisions of the *Ontario Heritage Act* to designate and preserve buildings, structures, or landscapes (BWG OP, 3.8.1.a). These policies align with the objectives and goals presented in the Bond Head HCD Plan.

### 4.2 Town of Bradford West Gwillimbury Zoning By-Law

The Zoning By-Law specifies and regulates the permitted use and building standards in each of the zoning categories. Of the properties located within the heritage conservation district, majority are zoned Rural Settlement Residential and Future Development. Also found within the district are properties zoned Institutional, Open Space, Environmental Protection, Rural Settlement Commercial, with some site-specific Rural Settlement Residential, Residential One, and Rural Settlement Commercial properties. All proposed works within the District is required to comply with the Zoning By-Law and associated regulations.

### 4.3 Site Plan Control

Site Plan Control is a process that requires the preparation of detailed site-specific development plans, and enables the review of such matters as building location, and massing, access, outdoor storage, amenity space, walkways, landscaping, loading and parking facilities, accessibility, lighting, grading and external non-design features (BWG OP, 8.0). The Site Plan Control policies in the BWG *Official Plan* can be used as a tool for ensuring that the objectives, policies and guidelines of the HCD Plan are met for alterations to existing buildings and for new developments proposed within the Bond Head HCD. Under Section 41 of the *Ontario Planning Act*, a municipality can designate the whole, or any part of, an area as a site plan control area through the *Official Plan*.

### 4.4 Demolition Control

In accordance with the *Planning Act*, the Town may pass a by-law establishing areas of demolition control (BWG OP, 7.1.8). In instances where an application to demolish a designated heritage resource is submitted, it must be considered in accordance with the provisions of the *OHA* and

the Town's OP (BWG OP, 7.1.8). Through the *OHA* Section 42 allows municipalities to prevent the demolition or removal of buildings within heritage conservation districts prior to obtaining a permit. As a result, once a HCD is established, additional regulations from the *OHA* apply that seek to protect against the loss of heritage resources. Further, the *OHA* holds that if a municipal heritage committee has been established, the committee must be consulted on all applications for demolition permits in the HCD.

#### **4.5 Property Standard By-Law**

The Town By-law 98-065 establishes and enforces minimum standards for the maintenance and occupancy of all property within the Town. All buildings, dwellings, dwelling units, and lands are subject to this By-law to protect the safety, health, and welfare of occupants. The By-law prohibits the occupancy or use of properties that do not conform to the standards and requires that properties not in conformance with the standards be repaired and maintained to ensure conformity. The by-law outlines requirements for exterior property areas, including yards, fencing, compost heaps, and garbage disposal as well as standards for buildings and structures. There are no requirements in the by-law relating to the exterior of heritage buildings; however, amendments to the by-law are not recommended. Policies and guidelines of this Plan, in combination with the existing Property Standards By-law are sufficient to protect heritage assets within the Bond Head HCD.

## 5.0 PROPERTY STATUS

As part of the HCD Study, each property underwent a review using the criteria outlined in Ontario Regulation 9/06. The evaluation was subsequently updated to reflect O. Reg. 569/22 amendments. These criteria relate to design or physical value, historical or associative value and contextual value.

### 5.1 Part IV – Individual Property Designation Status

A Part IV designation is associated with a property which possess cultural heritage value specific to only that property. Individual properties located within a District may be designated under Part IV of the *Ontario Heritage Act*, for their individual cultural heritage value, as well as under Part V. Properties currently subject to Part IV designations include:

- 4370 Line 7 (Brazell-Chambers House-By-Law 1983-65)

This property, and any other properties which may seek to be recognized under Part IV of the *OHA* after the creation of the District, would be subject to both the Objectives, Policies, and Guidelines outlined in this District Plan and the conservation requirements outlined in their Part IV designation by-laws, as per Sections 33 and 34 of the *OHA*.

### 5.2 Part V – Status Within the District

A Part V designation is associated a group of buildings which together possess cultural heritage value. All properties, both public and private, in the District add to the District value, and are designated under Part V of the *Ontario Heritage Act*. This is a legal designation that is registered on title. The District's heritage attributes, and those associated with the individual property Statement of Contribution are expected to be conserved.

**At least 25 per cent of the properties within the municipality or defined area or areas satisfy two or more of the following criteria outlined in O. Reg 569/22:**

- The properties have design value or physical value because they are rare, unique, representative or early examples of a style, type, expression, material or construction method.
- The properties have design value or physical value because they display a high degree of craftsmanship or artistic merit.
- The properties have design value or physical value because they demonstrate a high degree of technical or scientific achievement.
- The properties have historical value or associative value because they have a direct association with a theme, event, belief, person, activity, organization or institution that is significant to a community.
- The properties have historical value or associative value because they yield, or have the potential to yield, information that contributes to an understanding of a community or culture.
- The properties have historical value or associative value because they demonstrate or reflect the work or ideas of an architect, artist, builder, designer or theorist who is significant to a community.
- The properties have contextual value because they define, maintain or support the character of the district.
- The properties have contextual value because they are physically, functionally, visually or historically linked to each other.
- The properties have contextual value because they are defined by, planned around or are themselves a landmark

### 5.3 District Property Status

There are two classes of properties found in the District:

- **Contributing Properties** – Property met two or more criteria outline in O. Reg 569/22
- **Supporting Properties** – Property did not meet two criteria outlined in O. Reg 569/22

#### 5.3.1 Property Class: Contributing and Supporting

**Contributing properties** demonstrate one or more of the key attributes or values that individually or in combination with the public realm reflect the distinct character of the District. Contributing properties exhibit physical heritage attributes which directly contribute to the cultural heritage value or interest of the District in their design or physical value, historical or associative value, or contextual value.

Contributing properties are subject to the policies outlined in Section 6.2 and Guidelines outlined in Section 7.0.

**Supporting properties** do not demonstrate one or more of the key attributes or value that individually or in combination with the public realm reflect the distinct character of the District. They do not meet two or more of the criteria outline in O. Reg 569/22 and therefore do not exhibit design or physical value, historical or associative value, or contextual value. Many buildings in the District are considered supporting and reflect infill and village-edge development made up of a variety of postwar buildings.

Supporting Properties are subject to the policies outlined in Section 6.3 and Guidelines outlined in Section 7.0.

Table 1 shows the properties and their respective status. Appendix A. provides the Statement of Contribution for each property and outlines the heritage attributes.

#### PROPERTY VS. BUILDING

Throughout the District Plan, specifically the goals and objectives (Section 3.0) and district policies (Section 6.0) sections, the terms *Contributing building* and *Contribution property* has been used interchangeable depending on the nature of the discussion. The use of the word *building* is to provide clarity for the reader only. Any use of the word **Contributing**, inherently applies to the entire property parcel.

Similarly, the terms *Supporting building* and *Supporting property* have also been used interchangeably through the District Plan. Any use of the word **Supporting**, inherently applies to the entire property parcel.

**Table 1: Property Status in the District**

Property Address	Contributing Property	Property Address	Contributing Property
56 Hearn St.	✓	2891 County Rd. 27	✓
62 Hearn St.	✓	2897 County Rd. 27	
70 Hearn St.	✓	2901 County Rd. 27	✓
2940 County Rd. 27		2907 County Rd. 27	✓
4354 Line 7	✓	2921 County Rd. 27	✓
4360 Line 7		4335 County Rd. 88	✓
4364 Line 7		4331 County Rd. 88	✓
4370 Line 7	✓	4329 County Rd. 88	
4376 Line 7		4325 County Rd. 88	✓
4382 Line 7		4319 County Rd. 88	
21 Hearn St.		4313 County Rd. 88	✓
16 Hearn St.		4307 County Rd. 88	
4392 Line 7		4303 County Rd. 88	
4396 Line 7		4297 County Rd. 88	✓
1 Dixon Rd.	✓	4289 County Rd. 88	✓
4377 Line 7		4208 County Rd. 88	✓
4371 Line 7		4221 County Rd. 88	✓
4365 Line 7		4222 County Rd. 88	✓
4359 Line 7	✓	4228 County Rd. 88	✓
4353 Line 7		4240 County Rd. 88	✓
2930 County Rd. 27	✓	4252 County Rd. 88	✓
2922 County Rd. 27		4260 County Rd. 88	
2912 County Rd. 27		4266 County Rd. 88	
2902 County Rd. 27	✓	4272 County Rd. 88	
7 Dixon Road	✓	4280 County Rd. 88	✓
2892 County Rd. 27	✓	4290 County Rd. 88	
2876 County Rd. 27	✓	4296 County Rd. 88	✓
2870 County Rd. 27	✓	4302 County Rd. 88	✓
2864 County Rd. 27	✓	4308 County Rd. 88	✓
2854 County Rd. 27		4312 County Rd. 88	
2848 County Rd. 27	✓	4314 County Rd. 88	✓
2843 County Rd. 27	✓	4318 County Rd. 88	✓
2853 County Rd. 27	✓	4320 County Rd. 88	✓
2875 County Rd. 27		4324 County Rd. 88	✓
2865 County Rd. 27		4330 County Rd. 88	✓
2881 County Rd. 27		4334 County Rd. 88	✓
2883 County Rd. 27		NE corner County Rd. 27 and 88	✓
2887 County Rd. 27	✓		

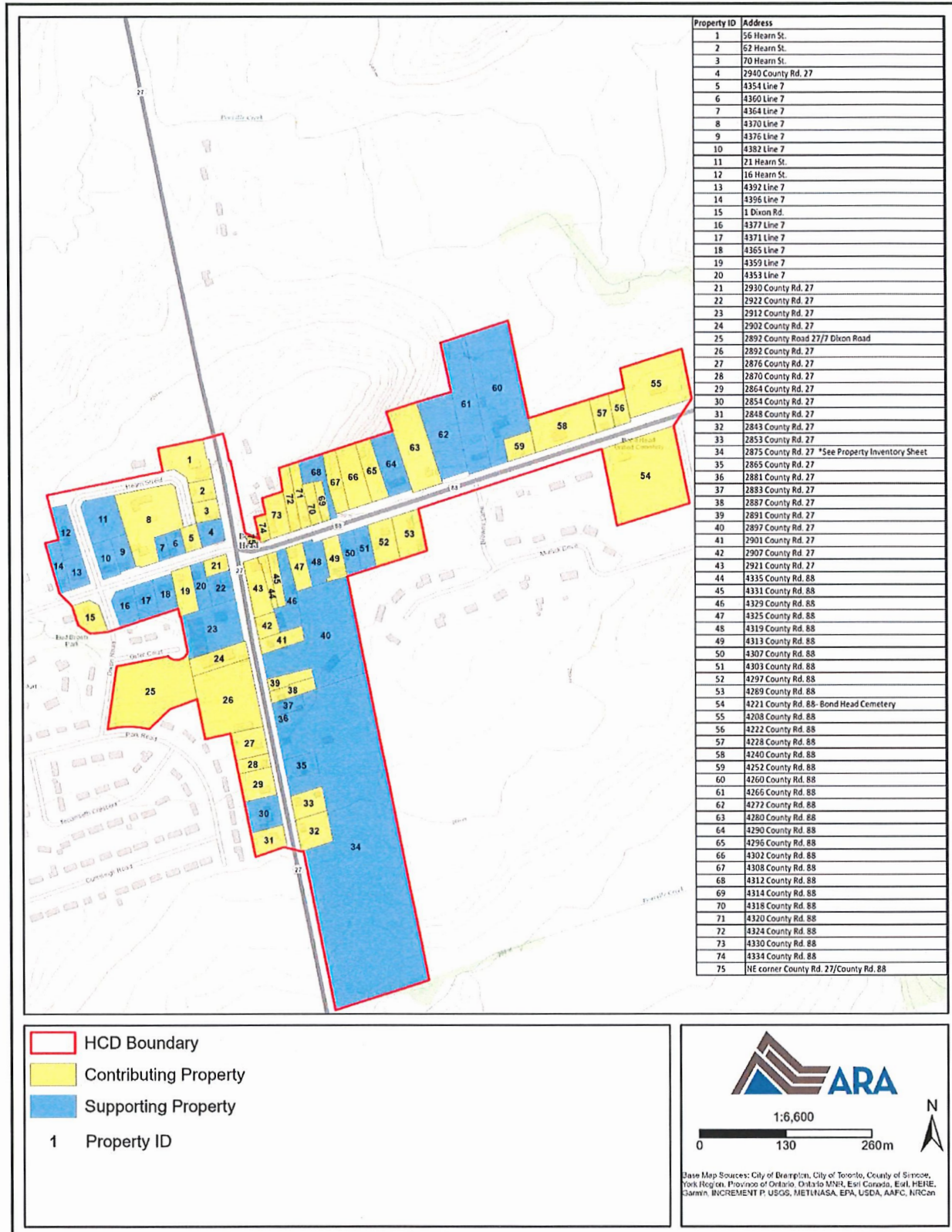

**Map 3: Property Status**  
 (Produced under licence using ArcGIS® software by Esri, © Esri)

## 6.0 DISTRICT POLICIES

The Policies are intended to operationalize the Objective of the District Plan outlined in Section 3.0. Policies are designed to lay out the specific action/s that should or should not be taken to conserve the cultural heritage value of the District.

Where a proposed change does not lend itself to the specific requirements of the District Plan, the onus is on the proponent to demonstrate how the proposed change meets the Objective of the Plan and rationalize any deviation from the Plan.

This section provides the Policies that must be considered by City Staff, Committees, Council, and property owners, when reviewing proposals or applications for decision making regarding changes to the District and properties within the District. Guidelines to further illustrate the intent of the policies are provided in Section 7.0.

### 6.1 Development Patterns

The District contains single-family residential areas, a commercial core, parks and open spaces, and institutional properties. To maintain the general consistency of the land uses and development patterns in the District, the following policies apply:

#### **Policies:**

- a. Maintain the human scale by ensuring that the low density (one to three storeys) residential land-use character remains dominant.
- b. Where new uses or intensification of an existing property is proposed, adaptive reuse of the existing heritage building stock shall be considered.
- c. Conversion of use will be permitted, should the change in use be permitted in the Town's Zoning By-Law and if the conversion does not significantly alter the street appearance of the building.
- d. Severances which would create new lots are strongly discouraged, unless the resulting lot sizes are of comparable size and depth to existing adjacent lots.
- e. If a building is lost due to unfortunate circumstances (i.e. fire) the setback of replacement buildings shall be consistent with the original building or set back to be in accordance with the adjacent properties.
- f. Lot patterns and building setbacks shall be maintained. Significant changes to the existing building placement and setbacks shall be discouraged.

### 6.2 Policies for Contributing Properties

#### **6.2.1 Alterations and Additions to Contributing Buildings**

The District Plan fully anticipates that alterations and/or additions to accommodate modern-day living needs and the personalized needs of the individual and community. However, it is important that any addition/s and alteration/s are compatible and do not detract from the overall heritage character of the neighbourhood and do not result in the loss of noted heritage attributes. These policies are included to reinforce the heritage values and character of the District:

#### **Policies:**

- a. Alterations to Contributing buildings shall conserve the heritage attributes which are listed in the property's Statement of Contribution.

- b. Adaptive and sensitive reuse of Contributing buildings which maintain the architectural style and heritage attributes is encouraged.
- c. Minor exterior additions to existing Contributing buildings shall be permitted provided that they are positioned at the rear and/or side elevation and do not significantly detract from, overpower, or alter the building façade.
- d. Any known original construction detail or features on a Contributing building should be encouraged to be reinstated, retained, and repaired whenever possible.
- e. Any exterior stairs or fire escapes should be located away from the front or street facing façade of the building when possible.
- f. Where possible, alterations to Contributing properties should include removal of any layers of unsympathetic work, materials, or features and the restoration of original features and detail is encouraged.
- g. If a heritage attribute requires replacement or alteration, it shall be undertaken in a sympathetic manner, in accordance with the design guidelines in Section 7.0.
- h. Where applicable, the size and scale of commercial signs shall be compatible with, and sensitive to, the existing building and shall have regard for the surrounding area. Signs that obscure architectural details or prominent views are discouraged.
- i. Alterations and additions shall be designed to be compatible with and respect the heritage character of the District through attention to height, built form, setback, massing, material, orientation, relationship to the street, and other architectural or physical elements.
- j. Additions to Contributing buildings shall be located at the rear or side of the building and designed to be:
  - o Sympathetic and subordinate to the building's heritage attributes by considering, but not limited to, scale, massing, roof pitch, colour, style, and materials.
  - o Of a high-quality design or architecture
  - o Be respectful of the heritage attributes of the building while appearing to be a product of their time.

### **6.2.2 Demolition**

One of the key Objectives of the District is to protect and conserve heritage resources both in the short term and for future generations. Nevertheless, it is understood that there are situations where full or partial demolition may be necessary or required. In these instances, the following policies apply:

#### **Policies:**

- a. Contributing buildings in the District shall not be demolished and shall remain in-situ within the existing context until any required study (studies) which demonstrate all options for adaptive re-use, retention, or integration of the existing structures has been fully explored to the satisfaction of the Town.
- b. The demolition of a Contributing building in the District, which has been deemed structurally unstable by a qualified professional and/or determined to be beyond any reasonable conservation treatment or repair by a qualified professional shall not be permitted until any required study (studies) have been completed. This determination will be at minimum through a Heritage Impact Assessment and/or relevant studies to the satisfaction of Town staff, the Heritage Committee, and Council.
- c. In situations where demolition has gone through the planning process and been approved by Council. It is recommended that full documentation with written and/or photographic documentation shall be undertaken by a heritage professional. This includes recording

any notable architectural features and construction techniques to create a record of the building and its components.

- d. In situations where demolition has gone through the planning process and been approved by Council, the salvage and reclamation of suitable building materials (such as windows, doors, mouldings, columns, bricks, etc.) is strongly encouraged.

### **6.3 Policies for Supporting Properties**

Supporting properties have the potential to contribute and/or detract from the District character. It is important that any addition/s and alteration/s to Supporting buildings are compatible with neighbouring properties, do not detract from the overall heritage character of the neighbourhood and do not result in the loss of key heritage attributes of the District.

#### **6.3.1 Alterations and Additions**

##### **Policies:**

- a. Supporting properties shall be maintained and not purposefully left vacant and in a state of disrepair according to the Property Standards By-law and Clean Yards By-law.
- b. Alterations and additions to Supporting properties shall be considered based on the site-specific understanding the property and its contribution to the District's cultural heritage value.
- c. Alteration/s and/or additions on Supporting properties shall not detract from the overall aesthetic of the streetscape, adjacent properties, and the character of the District.
- d. Where alterations or additions are planned on Supporting properties, interventions are not required to follow or mimic a particular historic architectural style provided that the contemporary design takes its design cues from the surrounding context as stated above.

#### **6.3.2 Demolition**

##### **Policies:**

- a. Demolition of Supporting buildings without a proposed new development or plan is discouraged.
- b. Demolition of Supporting buildings will generally be permitted when a proposed new development is planned and are subject to policies outlined in Section 6.4.

### **6.4 New Development**

Within the District, there are few areas where new buildings could be constructed without the relocation or demolition of existing buildings. Nonetheless, there may be circumstances where infill or new development is possible in the future or where redevelopment is proposed as a result of the loss of buildings. In these situations, the following policies regarding new development or infill apply.

##### **Policies:**

- a. New buildings shall be designed to be compatible with and respect the heritage character of the District through attention to height, built form, setback, massing, material, orientation, relationship to the street, and other architectural or physical elements.
- b. New buildings shall contribute to the sense of place of the District and shall not negatively impact or detract from the heritage character of the adjacent buildings, streetscape and overall District.

- c. Design guidelines provided in Section 7.0 of this Plan will be used to review and evaluate any proposals for new buildings in order to ensure compatibility with the adjacent properties and community context.
- d. New development is permitted on land/s where:
  - o No building exists and/or a vacant lot.
  - o A Contributing building existed and was demolished in conformity with the policies and guidelines in the District Plan.
  - o A Supporting building is being replaced.

## 6.5 Streetscape and Public Realm

In order to ensure that the streetscape and its associated features and elements in the District are considered, the following policies apply to all properties:

### Policies:

- a. The rural profile of the roads and roadways should be maintained and enhanced.
- b. Any upgrades or replacement to vehicle or pedestrian roadways, shall consider the character of the area and significant views.
- c. All public work improvements shall be designed, sited, and implemented with consideration for the District values and attributes as defined in the Statement of Cultural Heritage Value
- d. Any installation of fencing, lighting, and hard landscaping shall consider the District character and shall be sympathetic to the area.
- e. Alterations to the existing landscaping or public features shall employ natural materials in keeping with the District character. Concrete and hard landscaping shall be discouraged.
- f. Bud Brown Memorial Park and Audrey Wychopen Memorial Park shall be maintained as public open parks and enhanced through the inclusion of high-quality design or features.
- g. Maintain and where possible, enhance, the walkability within the District.
- h. Mature street trees are to be protected and preserved where possible. If removal of street trees is deemed necessary, the Town should work with the County to determine if replacement is feasible. Tree species within the Heritage District should aim to include native species which have been found historically in public parks and urban areas (i.e. Sugar Maple, Red Maple, Silver Maple, White Oak, Red Oak, Hickory, Walnut. Heritage perennials and shrubs).
- i. The Town is encouraged to implement a street tree succession planting program to ensure the long term inclusion of trees along the streetscape and in the public realm. Replacement trees may include heritage-suited species such as Sugar Maple, Silver Maple or Oak.
- j. Universal accessible design shall be introduced within public areas when there are proposed upgrades to infrastructure. This should be done in a manner that does not severely impact or detract from the character of the District.

## 6.6 Implementation

- The Town shall encourage representation on the Heritage Committee from a member of the District and/or facilitate the development of a resident liaison/review body who will work with the Town to aid in the Heritage Permit Review process.
- Any approvals for municipal works projects which directly contradict the Objectives of this Plan shall require review and follow the Heritage Permit Review Process.
- The District Plan prevails in the event of a conflict between the District Plan and any municipal by-law.

- Administration of the District Plan should be designed to be simple, efficient, and transparent.
  - There should be no additional fee to submit Heritage Permits.
  - Delegated authority to planning staff to approve minor heritage permits shall be integrated into planning frameworks.
  - A Heritage Impact Assessment Terms of Reference should be established to be used in the planning process as needed.
  - Assistance from the Town should be available to applicants submitting Heritage Permits in order to help them understand and comply with District policies and Guidelines.
  - The Plan should be periodically reviewed and updated if necessary.

## 6.7 Part IV Designations

The Policies and Guidelines of the District Plan are to apply to any property previously designated under Part IV of the *Ontario Heritage Act*.

In addition to the Policies and Guidelines outlined in this Plan, any and all interior and exterior heritage attributes previously designated under Part IV of the *Ontario Heritage Act*, will continue to be protected equivocally as prior to their designation under Part V.

## 6.8 Adjacent Property

The PPS outlines that mitigative measures or alternative development approaches may be necessary to ensure that the protected heritage attributes are not affected by adjacent development. To ensure that any proposed development or redevelopment outside of, but directly adjacent to the District, has considered the Plan, the following policies apply:

- a. At minimum, a Heritage Impact Assessment, with be required for any development proposals adjacent to the District.

## 7.0 DISTRICT GUIDELINES – EXPLAINED

### 7.1 Purpose and Organization

Design guidelines are required for the District to manage physical changes and are prepared with the following objectives in mind:

- Protect and maintain the cultural heritage attributes of the District.
- Allow for growth within the District, yet manage change.
- Protect and enhance the village character of Bond Head for the benefit of the community.

In response, the purpose of the District Plan is to ensure that property owners’ respond to change by selecting building forms, materials, construction methods, and site layouts that preserve the community village character and sense of place of the District. ‘Best Practice’ guidelines are noted in each section and are intended to be the benchmark standard for all minor and major physical alterations within the District boundary. As such, the Town encourages property owners to meet these guidelines wherever possible when making alterations to their property.

<b>KEY Definitions</b> (See Section 9.0 for full list)
<p><b>Alteration:</b> “alter” means to change in any manner and includes to restore, renovate, repair or disturb and “alteration” has a corresponding meaning (<i>OHA</i>). [Note: ‘Disturb’ is interpreted as being applicable to archaeological sites];</p> <p><b>Best Practices:</b> ‘Best Practice’ guidelines are noted in each Section and are intended to be the benchmark standard for all minor and major physical alterations within the District boundary. As such, the Town encourages property owners to meet these guidelines wherever possible when making alterations to their property</p> <p><b>In kind:</b> with the same form, material, and detailing as the existing (S&amp;G 2010:254).</p> <p><b>Maintenance:</b> Routine, cyclical, non-destructive actions necessary to slow the deterioration of a historic place. It entails periodic inspection; routine, cyclical, non-destructive cleaning; minor repair and refinishing operations; replacement of damaged or deteriorated materials that are impractical to save (S&amp;G, 2010: 254).</p>

The design guidelines are divided into the following sections:

**Alterations to Contributing Residential and Non-Residential Buildings (8.1 & 8.2):** Both residential and non-residential buildings contribute to the heritage value of the District. The design guidelines for Contributing properties focus on maintenance and repair, as well as sympathetic alterations. This section also includes additional guidelines for non-residential buildings in the District regarding storefronts and entrances, signage, lighting, and awnings.

**Additions to All Buildings (8.3):** This section provides guidelines for the design of new additions to existing buildings in the District. Additions must be sympathetic to the heritage character of the District through their scale and massing, location and orientation, and materials. Guidelines within this section apply to all existing buildings within the District, whether they currently contribute to the heritage value of the District or have the potential to support the District Objectives.

**Secondary Structures on All Properties (8.4):** Secondary structures include attached and detached garages, sheds, barns, and other outbuildings. Secondary structures that contribute to the heritage character of the District should be maintained. New secondary structures should be complimentary to the primary structure on the property and also sympathetic to the heritage character of the District.

**New Construction (8.5):** This section provides guidelines for new construction within the District. New construction must be sympathetic to the heritage character of the District through scale and massing, location and orientation, and materials.

**Demolition (8.6):** These guidelines apply to the full and partial demolition of buildings and structures on Contributing and Supporting properties in the District. Demolition of Contributing buildings is strongly discouraged. The design of replacement buildings must comply with the guidelines for new construction and/or additions and must be approved in principle by the Municipality prior to any demolition.

**Accessibility (8.7):** Ease of access to and around buildings should be considered when constructing additions and new buildings. These guidelines ensure accessible solutions including ramps and handrails are compatible with the exterior form of existing buildings. Barrier-free accessibility should be provided to all non-residential buildings, as required by AODA and the OBC.

**Mechanical/Electrical Services and Utilities (8.8):** Wherever possible, the placement of new mechanical and electrical fixtures, utilities, and sustainable building components, including solar panels, should not degrade the heritage character of the District. These guidelines encourage property owners to carefully consider the positioning of new service fixtures and elements.

**Site Design/Landscaping (8.9):** This section provides guidelines for the conservation of existing landscape features that are integral to the overall appearance of the District. Sub-headings include trees and landscaping, landscape filters, fencing and screening, driveways, laneways and walkways, parking and access.

**Lot Severance and Assembly (8.10):** This section recognizes lot severances and refers property owners to the Municipality's Official Plan document. Lot severances within the District will be reviewed and permitted on a case-by-case basis.

**General Maintenance (8.11):** All buildings require general maintenance. General maintenance is required to ensure buildings, and their heritage attributes, do not fall into a state of disrepair. Routine monitoring and maintenance is essential to preserve the heritage character of the District. Specific mention is made to the cleaning of masonry buildings and best practices for removal of heavy soiling without damaging facades and eliminating all patina.

**Public Realm, Streetscapes and Parks (8.12 & 8.13):** The public realm includes buildings, streetscapes, and open space owned and maintained by the Municipality, such as Bond Head Community Memorial Hall and its surrounding greenspace, basketball courts and playground, and Audrey Wychopen Memorial Parkette with its park benches, memorial plaque and open greenspace.

## 7.2 Guidelines Background

### 7.2.1 Urban Design Guidelines

Where there is a conflict between documents (such as the Town Wide Urban Design Guidelines), this District Plan and Guidelines will govern.

## 7.3 Guideline Principles

The federal and provincial government have well established standards and guidelines in place for the conservation of heritage properties and identified heritage attributes. These standards and guidelines should be carefully reviewed and considered prior to undertaking any conservation work to a Contributing or Supporting property within the District.

The Ontario Ministry of Citizenship and Multiculturalism (MCM) has established the following "Eight Guiding Principles in the Conservation of Built Heritage Properties," that are often referenced when preparing HCD Plan guidelines. These principles were referenced while drafting the design guidelines for the District Plan.

### **Eight Guiding Principles in the Conservation of Built Heritage Properties**

1. Respect for Documentary Evidence:
  - Do not base restoration on conjecture: conservation work should be based on historic documentation such as historic photographs, drawings and physical evidence.
2. Respect for the Original Location:
  - Do not move buildings unless there is no other means to save them: site is an integral component of a building or structure. Change in site diminishes cultural heritage value considerably.
3. Respect for Historic Material:
  - Repair/conservé – rather than replace building materials and finishes, except where absolutely necessary: minimal intervention maintains the heritage content of the built resource.
4. Respect for Original Fabric
  - Repair with like materials: repair to return the resource to its prior condition, without altering its integrity.
5. Respect for the Building's History
  - Do not restore to one period at the expense of another period: do not destroy later additions to a building or structure solely to restore to a single time period.
6. Reversibility
  - Alterations should be able to be returned to original conditions. This conserves earlier building design and technique: e.g. when a new door opening is put into a stone wall, the original stones are numbered, removed and stored, allowing for future restoration.
7. Legibility
  - New work should be distinguishable from old: buildings or structures should be recognized as products of their own time, and new additions should not blur the distinction between old and new.
8. Maintenance
  - With continuous care, future restoration will not be necessary: with regular upkeep, major conservation projects and their high costs can be avoided.

The *Standards and Guidelines for the Conservation of Historic Places in Canada* also provide general standards for preservation, rehabilitation, and restoration with further explanation regarding how these standards should be applied. A few notable standards applicable to these guidelines include the following:

- Repair rather than replace character-defining elements.
- Conserve the heritage value and character-defining elements when creating any new additions to an historic place or any related new construction. Make the new work physically and visually compatible with, subordinate to and distinguishable from the historic place.
- Create any new additions or related new construction so that the essential form and integrity of an historic place will not be impaired if the new work is removed in the future.

The *Standards and Guidelines for the Conservation of Historic Places in Canada* were used as guiding principles for drafting the Bond Head HCD Plan guidelines.

<p><b>Conservation Terms:</b></p> <p><b>Beyond Reasonable Repair</b> – when the severity of the deterioration makes repair of a building component impractical.</p> <p><b>Rehabilitate</b> = Alter</p> <p><b>Renovate</b> = Add or Modernize</p> <p><b>Conserve</b> = Repair or Fix</p> <p><b>Restore</b> = Rebuild</p> <p><b>Remodel</b> = Modernize</p> <p><b>Convert</b> = Add or Change</p>
---

## 8.0 BOND HEAD HERITAGE DISTRICT GUIDELINES

### 8.1 Alterations on Contributing Residential and Non-Residential Buildings

#### 8.1.1 Roofs, Parapets and Chimneys

Roofs are integral to keeping buildings watertight and can also have a significant visual impact on a streetscape. Roof elements including church steeples, finials and chimneys can act as landmarks and visual aids. Decorative fascia and gables are prevalent within the District and contribute to the heritage value of the village. Roofs in the District are largely covered with asphalt shingles and metal standing seam roofing.

#### Best Practices

- Document the form, materials and condition of the roof assembly before undertaking any intervention, including the roof's pitch, shape, decorative and functional elements, and materials, and its size, colour and patterning.
- Determine the cause of the roof's distress, damage or deterioration through investigation, monitoring and minimally invasive testing techniques. Address signs of distress, damage and deterioration as soon as possible.
- Protect and maintain the form and rooflines of original buildings.
- Protect and maintain original detailed elements including but not limited to fascia, cornice, eaves, gables, and trim.
- Protect and maintain a roof by cleaning and maintaining the gutters, downspouts and flat roof drains, and replacing deteriorated flashing in kind.
- Retain sound or deteriorated roof assemblies that can be repaired.

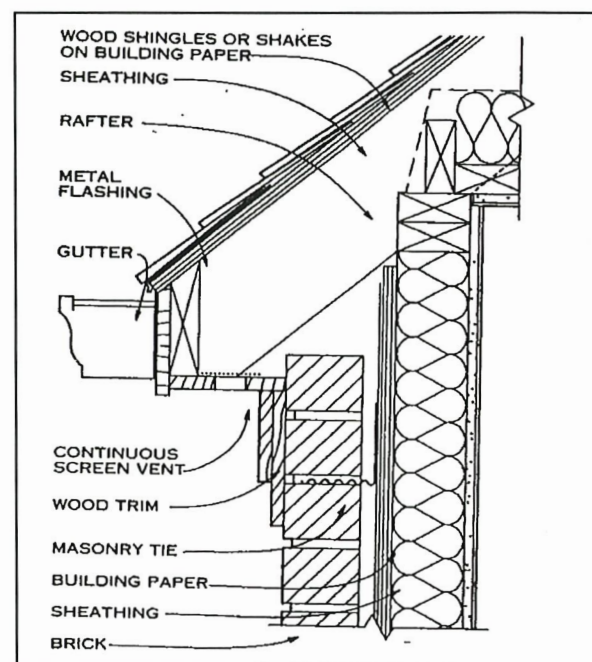

Eave at Brick Veneer (Source: Graphic Standards)



56 Hearn St. (left) and 2876 County Rd. 27 (right)  
(Source: GDV)

- Repair parts of roofs by patching, piecing-in, consolidating, or otherwise reinforcing, using recognized conservation methods. Repairs should match the existing work as closely as possible, both physically and visually.
- Where roofing is extensively deteriorated or missing, replace in kind. Use salvaged material wherever possible or new materials that match the original style and quality of the originals.
- Improve the detailing of roof elements, including installation of flashing and crickets, following recognized conservation methods, to correct faulty details. Such improvements should be physically and visually compatible.
- Where physical and documentary evidence exists, the reinstatement of original features and materials such as slate or wood shingles, chimneys, finials and other roof elements can further contribute to the heritage character of the District.
- Removal of elements that conceal original architectural details is encouraged (i.e., removal of vinyl or metal soffits and fascia can help to reveal the building's original character).
- Historic wood details such as eaves, soffits, finials, gingerbread, and other gable details form part of the original architectural design of Contributing buildings in the district and must be maintained. These details should not be clad with vinyl or aluminum since this conceals their original aesthetic and also prevents proper monitoring and maintenance.



2870 County Rd. 27 – Gable details  
(Source: GDV)



4318 County Rd. 88 – gable and final details  
(Source: GDV)

### Acceptable Roofing Materials

Existing roofing materials in the District largely consist of either asphalt shingles or metal roofing. Roofing material is generally neutral in colour with a few rare examples of red, green etc.

- The use of asphalt shingles and metal roofing is generally acceptable in the District. Select profiles and colours that are compatible with other Contributing buildings in the District. Metal standing seam roofing is acceptable as well as neutral colours.
- Avoid selecting roofing materials including plastic and ceramic that do not traditionally appear in the District.

**Chimneys**

- Protect and maintain original chimneys including capping and flashings.
- Repair masonry chimneys using recognized conservation methods including repointing and selective replacement. Repairs should match the existing work as closely as possible.
- Where chimneys are extensively deteriorated or missing, replace in kind where there is historic documentation of the originals. Wherever possible, refrain from demolishing existing original chimneys, especially when there is no intent to reconstruct.

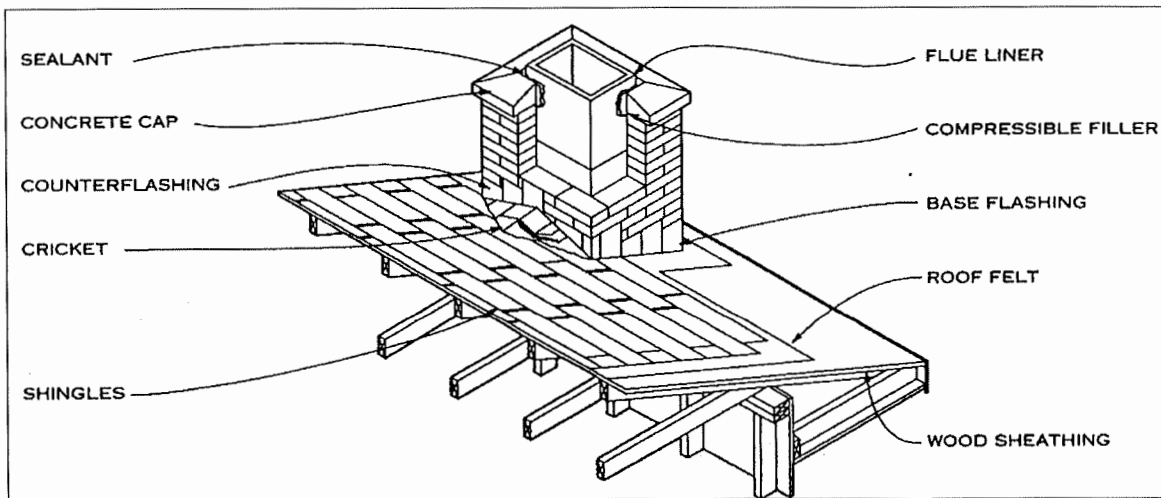

Parts of a Chimney (Source: Graphic Standards)

**Eavestroughs and Downspouts**

- Protect and maintain original eavestroughs, downspouts and flashing wherever possible.
- Where documentary evidence of original eavestrough and downspout profiles exist, the reinstatement of these features is encouraged.

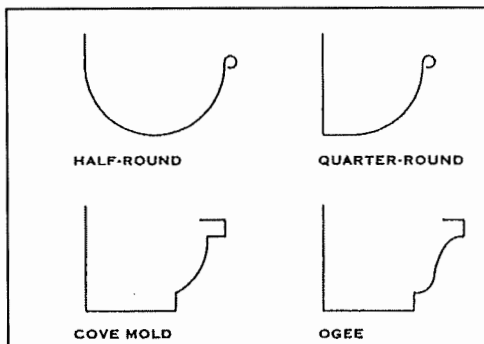

Typical Gutter and Downspout Shapes (Source: Graphic Standards)

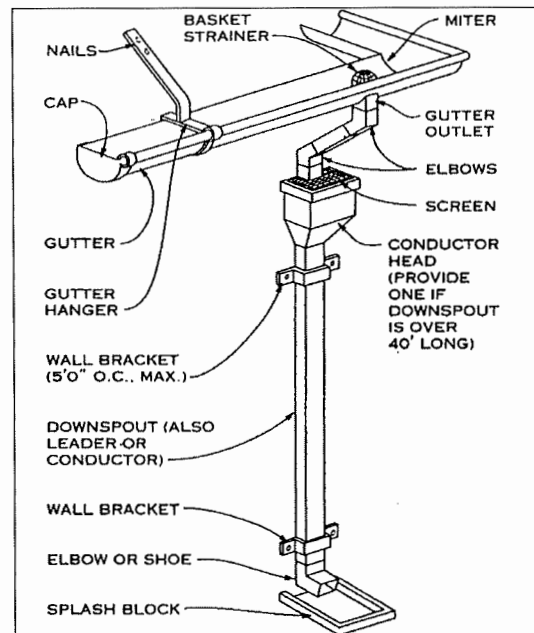

Parts of a Gutter/Downspout System (Source: Graphic Standards)

### 8.1.2 Exterior Walls

Exterior walls of Contributing buildings in the District are largely either brick masonry construction or wood framed walls with wood siding. Other exterior cladding materials for Contributing buildings include vinyl siding, wood board and batten, and stucco. Exterior walls often contribute to the heritage value of buildings through their form, use of materials and detailing. This is especially evident in the collection of residential buildings at the village crossroads in the District. These buildings display the use of dichromatic brickwork where red brick is used as the dominant field colour and buff brick is used for detailing including quoins and corner details, window and door headers, and horizontal patterns or banding.

#### Best Practices

- Document the composition, form, materials, details, dimensions and condition of exterior wall assemblies before undertaking any intervention.
- Determine the cause of any distress, damage or deterioration through investigation, monitoring and minimally invasive testing techniques. Address signs of distress, damage and deterioration as soon as possible.
- Protect and maintain exterior walls by cleaning and repairing damaged materials, and checking for moisture penetration and insect infestation, taking corrective action, as necessary and as soon as possible.
- Retain sound or deteriorated exterior wall assemblies that can be repaired.
- Stabilize exterior walls by using structural reinforcement, weather protection, or correcting unsafe conditions, as required, until repair work is undertaken.
- Repair parts of exterior walls by patching, piecing-in, consolidating, or otherwise reinforcing, using recognized conservation methods.
- Protect and maintain dichromatic brickwork including, but not limited, field brick, quoins and corner details, window and door headers, horizontal patterns.

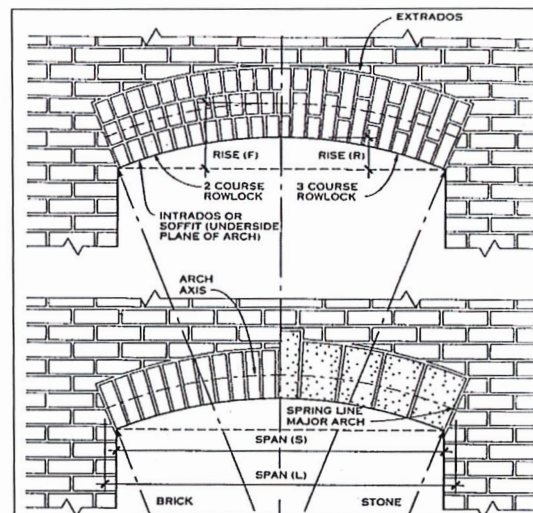

**Types of Segmental Arches**  
(Source: Graphic Standards)



4330 County Rd. 88 – Gothic Revival Cottage with dichromatic brickwork  
(Source: GDV)



4324 County Rd. 88 – Gothic Revival Residence with dichromatic brickwork  
(Source: GDV)

- Where original masonry and cladding is extensively deteriorated or missing, replace in kind. Use salvaged material wherever possible or new materials that match the original style and quality of the originals.
- Improve the drying ability of exterior wall assemblies through suitable heating and/or ventilation measures wherever possible.
- Refrain from covering over existing original exterior building materials with contemporary materials. Over cladding prevents proper monitoring and maintenance of the original exterior building materials. This includes painting unpainted brickwork. Instead, repair and/or replace the existing exterior building materials with like material.
- Where original masonry is concealed with later cladding materials (i.e., vinyl siding), removal and repair is highly encouraged and recommended. Use historic documentation to rehabilitate the exterior facades.



**Deteriorated mortar joints require repointing. Deteriorated joints are cut-out using handheld tools prior to repointing.**  
(Source: GDV)



**New lime rich mortar is applied to the joints. Repointing work is complete.**  
(Source: GDV)

### Avoid Over Cladding

When exterior building facades start to show signs of deterioration, some building owners decide to cover over the existing deteriorating materials in lieu of repair. This prevents proper maintenance of the original exterior building materials and can be detrimental to buildings. Applying paint to exterior masonry can also prevent buildings from breathing. Moisture can get trapped behind paint, further deteriorate the brick and cause severe damage.

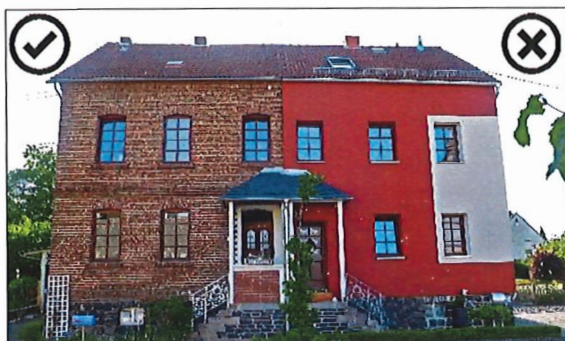

**An extreme example of over cladding where the right side of the brick masonry façade is covered with EIFS**  
(Source: Handwerker)

### 8.1.3 Windows

Windows often contribute to the heritage value of buildings. Windows are necessary for both functional and aesthetic purposes. They provide natural light and ventilation, exterior views, and access. Their size and arrangement are fundamental to a building's appearance and heritage value.

#### Best Practices

- Document the form, materials and condition of windows, and their elements, before undertaking any intervention. This includes the configuration, style, method of operation and materials.
- Determine the cause of distress, damage, or deterioration of windows through investigation, monitoring, and minimally invasive or non-destructive testing techniques. Address signs of distress, damage and deterioration immediately, so as not to cause further degradation.
- Protect and maintain the general arrangement, size, material and colour of existing original windows wherever possible.
- Protect and maintain windows by using appropriate surface treatments, such as cleaning, rust removal, limited paint removal, and reapplying protective coating systems in kind.
- Retain sound and repairable windows, including their functional and decorative elements, such as hardware, signs and awnings.
- Repair parts of windows by patching, piecing-in, consolidating, or otherwise reinforcing, using recognized conservation methods.

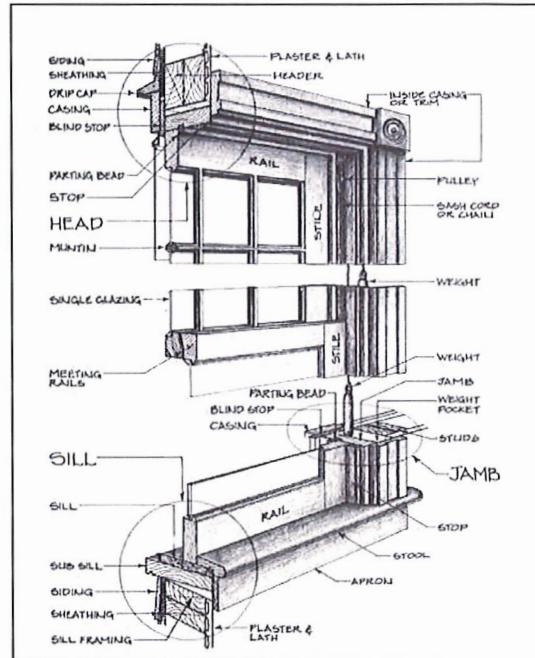

Exterior wood window components  
(Source: This Old House Online)



A selection of existing window styles in the District  
(Source: GDV)

- Where original windows are extensively deteriorated or missing parts, replace in kind where there are surviving prototypes. Use salvaged material wherever possible or new materials that match the original style, quality and operation of the originals.
- Where original windows are “beyond reasonable repair,” provide replacements to match the originals as close as possible. Avoid replacing original wood windows with aluminum, fiberglass or vinyl replacements. When replacing windows ensure adjacent architectural elements are also maintained.
- Where later contemporary windows require replacement, provide windows compatible with the original architectural style of the building in terms of design, materials, size, proportion, glazing and detailing.
- Avoid infilling original window openings. Removal of any existing infill for restoration of original window openings is encouraged.
- The provision of new window openings is generally discouraged, especially on front facades facing the street. Where new window openings are necessary, ensure they are compatible with the original architectural style of the building.



Example of window and exterior façade restoration / replacement based on historic documentation of originals. (Source: Standards and Guidelines)



Example of window restoration / replacement based on historic document of originals. (Source: GDV)

- The installation of weatherstripping and interior storm windows to improve thermal efficiency is supported.
- Wherever possible, locate window mounted air-conditioners away from front facades, including side elevations for corner lots.

**Window Shutters**

Shutters are moveable screens, typically made of wood, for filtering light and air. Historically, shutters were opened and closed on a routine basis however today they are seldom used for their original function and act more as decoration. When repairing and replacing shutters, ensure they are ½ the width of a window, attached at the window frame and constructed of louvered materials (angled slats or flat strips fixed or hung at regular intervals).

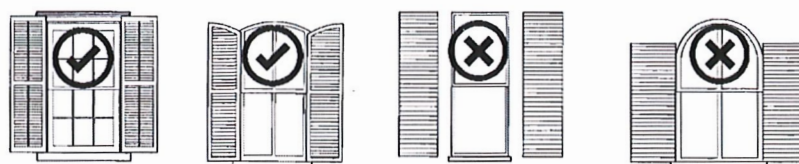

Examples of appropriate and inappropriate window shutter design (Source: Unionville HD Plan)

### 8.1.4 Entrances and Doors

Doors often contribute to the heritage value of buildings. Doors are necessary for both functional and aesthetic purposes. They provide natural light, exterior views, and access. Their size and arrangement are fundamental to a building's appearance and heritage value.

#### Best Practices

- Document the form, materials and condition of doors, and their elements, before undertaking any intervention. This includes the configuration, style, method of operation and materials.
- Determine the cause of distress, damage, or deterioration of windows, doors and storefronts through investigation, monitoring, and minimally invasive or non-destructive testing techniques. Address signs of distress, damage and deterioration immediately, so as not to cause further degradation.
- Protect and maintain the general arrangement, size, material and colour of existing original doors wherever possible.
- Protect and maintain doors by using appropriate surface treatments, such as cleaning, rust removal, limited paint removal, and reapplying protective coating systems in kind.
- Retain sound and repairable doors, including their functional and decorative elements, such as hardware, signs and awnings.
- Repair parts of doors by patching, piecing-in, consolidating, or otherwise reinforcing, using recognized conservation methods.

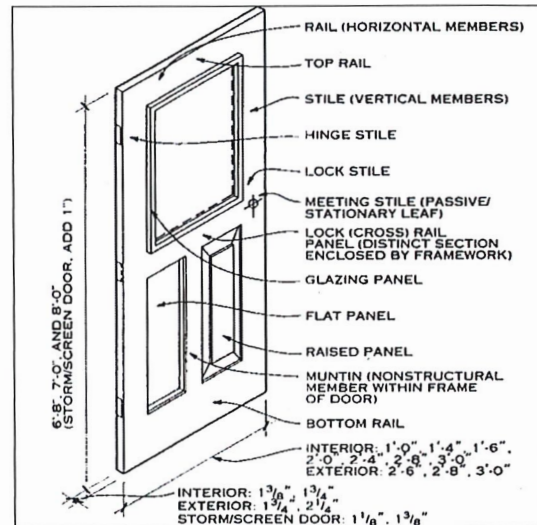

Typical Sizes and Characteristics of Wood Doors  
(Source: Graphic Standards)



4240 County Rd. 88 – entrance door with sidelights and transom  
(Source: GDV)



A selection of existing entrance doors in the District  
(Source: GDV)

- Where doors are extensively deteriorated or missing parts, replace in kind where there are surviving prototypes. Use salvaged material wherever possible or new materials that match the original style, quality and operation of the originals.
- Where original doors are “beyond reasonable repair,” provide replacements to match the originals as close as possible. Avoid replacing original wood doors with aluminum or fiberglass replacements. When replacing doors, ensure architectural elements around doors are also maintained.
- Where later contemporary doors require replacement, provide doors compatible with the original architectural style of the building in terms of design, materials, size, proportion, glazing pattern and detailing.
- The installation of weatherstripping and appropriately designed screen doors to improve thermal performance is supported.



A selection of existing entrance doors in the District  
(Source: GDV)

**Typical Door Styles**

Existing entrance doors in the District are largely made of wood and are consistent with the styles popular in Ontario in the late 19<sup>th</sup> and early 20<sup>th</sup> centuries. Existing original entrance doors are largely covered/protected with exterior screen doors. When repairing and replacing doors, ensure they are appropriate for the architectural style of the existing building.

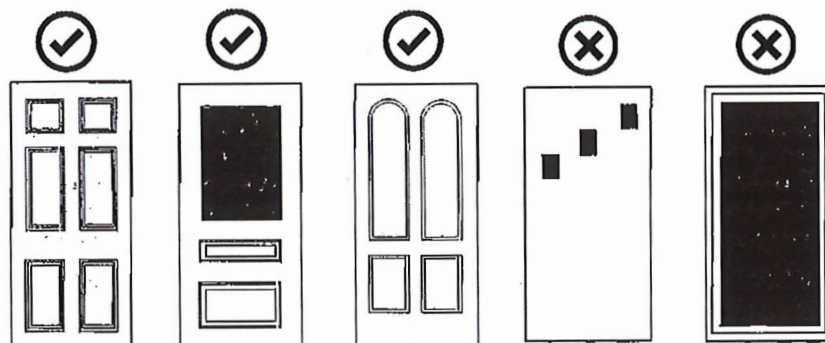

Examples of appropriate and inappropriate door styles  
(Source: Unionville HD Plan)

### 8.1.5 Porches, Porticoes, Verandahs and Balconies

Porches, porticoes, verandahs, and balconies are some of the most distinguishable features in the District. These features help to convey the village sensibility within the District, they connect people with the exterior environment and allow them to enjoy the outdoors while still being protected from the elements. One distinguishing element of numerous porches and verandahs in the District is the architrave detailing. An architrave is the lintel or beam resting across the tops of columns.

#### Best Practices

- Document the form, materials and conditions of porches, porticoes, verandahs and balconies before undertaking an intervention.
- Determine the cause of distress, damage or deterioration of porches, porticoes, verandahs and balconies through investigation, monitoring and minimally invasive testing techniques. Address signs of distress, damage and deterioration immediately, so as not to cause further degradation.
- Protect and maintain the form, arrangement and materials of existing original porches, porticoes, verandahs, and balconies wherever possible.
- Retain sound or repairable entrances, porches, porticoes, verandahs and balconies and their functional and decorative elements.
- Repair parts of porches, porticoes, verandahs or balconies by patching, piecing-in, consolidating, or otherwise reinforcing, using recognized conservation methods. Repairs should match the existing work as closely as possible, both physically and visually.
- Where porches, porticoes, verandahs and balconies are extensively deteriorated or missing parts, replace in kind where there are surviving prototypes. Use salvaged material wherever possible or new materials that match the original style and quality of the originals.



4370 Line 7 – Verandah  
(Source: GDV)



62 Hearn St. – front porch and former upper balcony  
(Source: GDV)



70 Hearn St. – Verandah  
(Source: GDV)

- Where a new element is added to an existing porch, i.e., railing, ensure the new element is compatible with the original architectural style of the building.
- The addition of new porches, porticoes, verandahs and balconies, especially those facing the street, is generally discouraged where they were not historically part of the building.
- Enclosing porches should be avoided and is discouraged as it may negatively impact the aesthetics of the building and the streetscape.



4334 County Rd. 88 – front porch  
(Source: GDV)

**Porch Additions**

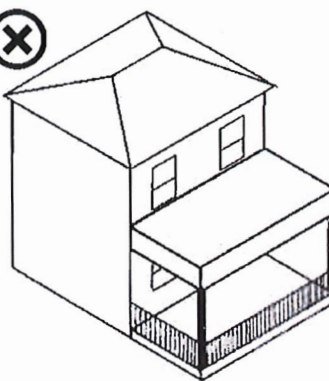
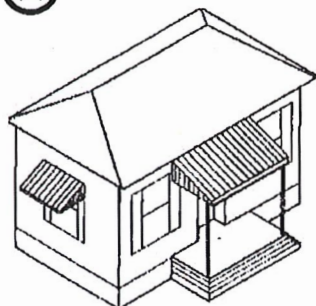
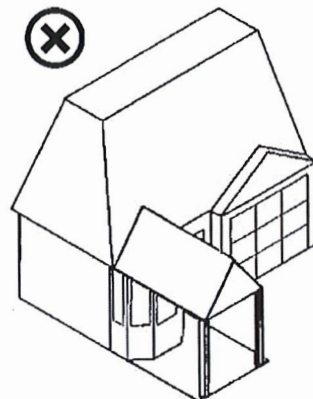
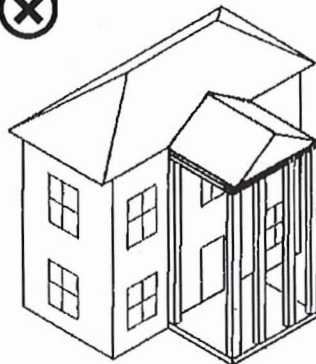
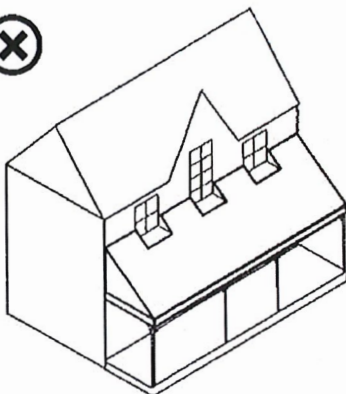

Porch additions to be avoided counterclockwise from top left: overly heavy porch cut into existing windows, Greek Revival columned porch, cart-port type of porch, enclave and Spanish porches, metal awnings, overly heavy flat porches. (Source: Unionville HD Plan)

**8.1.6 Foundations**

Original above-grade foundation walls should be protected and maintained wherever possible.

**Best Practices**

- Document the materials and conditions of foundations before undertaking an intervention.
- Determine the cause of distress, damage or deterioration of foundations thorough investigation, monitoring and minimally invasive testing techniques. Address signs of distress, damage and deterioration immediately, so as not to cause further degradation.
- Protect and maintain above-grade foundation walls by cleaning and repairing damaged materials, and checking for moisture penetration and insect infestation, taking corrective action, as necessary and as soon as possible.
- Retain sound or deteriorated foundation walls that can be repaired.
- Stabilize exterior walls by using structural reinforcement, weather protection, or correcting unsafe conditions, as required, until repair work is undertaken.
- Repair parts of foundation walls by patching, piecing-in, consolidating, or otherwise reinforcing, using recognized conservation methods.
- Where original foundations are extensively deteriorated, replace in kind. Use salvaged material wherever possible or new materials that match the original style and quality of the originals.
- Improve the drying ability of exterior wall assemblies through suitable heating and/or ventilation measures wherever possible.



**56 Hearn St. – Trinity Anglican Church  
Exposed stone foundation walls  
(Source: GDV)**

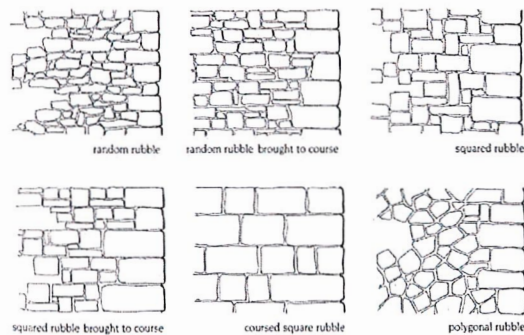

**Rubble construction patterns  
(Source: The Encyclopedia of New Zealand)**

- Refrain from covering over existing original foundations with contemporary materials including parging. This prevents proper monitoring and maintenance of the original exterior building materials. This includes painting unpainted masonry. Instead, repair and/or replace the existing exterior building materials with like material.
- Where original masonry is concealed with later cladding materials, removal and repair is highly encouraged and recommended. Use historic documentation to rehabilitate the foundations.
- Ensure downspouts and grading slopes are directed away from building foundations to minimize the risk of water damage and infiltration.

## 8.2 Additional Guidelines for Contributing Non-Residential Buildings

### 8.2.1 Storefronts and Entrances

Remaining storefronts contribute to the heritage value of the village. Their design, form and materials should be protected and maintained wherever possible.

#### Best Practices

- Document the form, materials and conditions of storefronts before undertaking an intervention.
- Determine the cause of distress, damage or deterioration of storefronts thorough investigation, monitoring and minimally invasive testing techniques. Address signs of distress, damage and deterioration immediately, so as not to cause further degradation.
- Protect and maintain the design, form and material of original storefronts including base panels, display/transom windows, and sign boards wherever possible.
- Retain sound or repairable storefronts and their functional and decorative elements.
- Repair parts of storefronts by patching, piecing-in, consolidating, or otherwise reinforcing, using recognized conservation methods. Repairs should match the existing work as closely as possible, both physically and visually.
- Replace in kind extensively deteriorated or missing parts where there are surviving prototypes. Use salvaged material wherever possible or new materials that match the original style and quality of the originals.
- Remove over cladding exterior building materials at historic storefronts and use historic documentation to rehabilitate the exterior façade.



4335 County Rd. 88 – existing vacant storefronts in the District (Source: GDV)



Historic photograph of commercial buildings in Bond Head (Source: Township of BWG)



Historic photograph of commercial buildings in Bond Head (Source: Township of BWG)



Examples of appropriate and inappropriate alterations to storefronts (Source: Unionville HD Plan)

### 8.2.2 Signage, Lighting and Awnings

The introduction of new signage, lighting and awnings must be carefully considered to ensure these new elements do not detract from the heritage character of the District.

#### Best Practices

- Protect and maintain original signage and lighting where existing.
- Repair original signage and lighting with like materials where damaged and/or deteriorated.
- Where documentary evidence exists, the reconstruction of period signage formerly found on the property may be appropriate for the design of a new sign.
- Install new signage, lighting and awnings sympathetic to the existing building that does not detract from the heritage value of the building and/or cover existing character-defining features.
- Follow the Municipality's signage by-law and obtain a permit prior to erecting any new signage.
- Incorporate signage in the valence of awnings, above storefronts, on canopies, sandwich boards, small scall projecting or hanging items, and window decals.
- When fastening signage to existing buildings use stainless steel hardware wherever possible and install fasteners into mortar joints.
- Select signs that are externally illuminated i.e., gooseneck lighting. Avoid the installation of internally illuminated and neon signage.



2892 County Rd. 27 – Community Memorial Hall  
Existing Signage (Source: GDV)



Example of window signage  
(Source: Orangeville Planning Dept.)

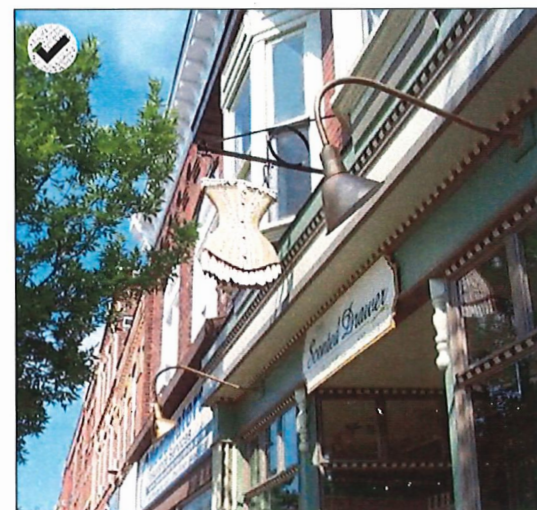

Example of projecting signage and gooseneck lighting  
(Source: Orangeville Planning Dept.)

## 8.3 Additions to All Buildings

### 8.3.2 General Guidelines

Additions to existing Contributing buildings are permitted however, they must be sympathetic and subordinate to the primary building.

- Consider accommodating new functions and services in non-character-defining interior spaces as an alternative to constructing a new addition.
- Select a new use that suits the existing building form.
- Maintenance of existing building additions that contribute to the architectural style of the original/primary building is encouraged.
- The addition of new storefronts is generally discouraged where they were not historically part of the original building.

### 8.3.3 Scale and Massing

The scale and mass of building additions must be carefully considered.

#### Guidelines

- Erect additions 1-2 storeys in building height, sympathetic in scale and massing to the primary building.
- Design a new addition in a manner that draws a clear distinction between what is historic/existing and what is new.
- Design rooflines for additions and new buildings so that they compliment the form, material and style of Contributing buildings within the District. This will help to reinforce the village setting and community vision for the District.
- Design additions so that the proportions, placement, style and materials of windows and doors compliment those of Contributing buildings within the District. This will help to reinforce the village setting and community vision for the District.
- Design new porches, porticoes, verandahs and balconies, so that they compliment the proportions, placement, style and materials of Contributing buildings within the District. This will help to reinforce the village setting and community vision for the District.

#### Dormer Additions

A dormer is a roofed structure, often containing a window, that projects vertically beyond the plane of a pitched roof. Design dormer additions to be sympathetic in scale and proportion with existing building features. Set new dormer additions away from the primary façade wherever possible.



Example of appropriate scale and massing for dormers (Source: GDV)

### 8.3.4 Location and Orientation

Additions should be placed so they are considered to be subordinate to the primary building on the property in size, stature and detailing.

#### Guidelines

- Select the location for a new addition that ensures the heritage value of the place is maintained.
- Set additions back from the primary building façade, especially where the addition faces a street.
- Where a new addition is erected to the rear of the existing building, and not visible from the public realm, contemporary designs that differ from their primary buildings may be permitted.
- Property owners are strongly encouraged to design new additions to be reversible so that the form and integrity of the original building is maintained and not compromised should the addition be removed at a later date.
- Locate contemporary roof features including skylights, solar panels, green roofs so that they do not visually impact views of neighbouring properties or viewscales within the District.

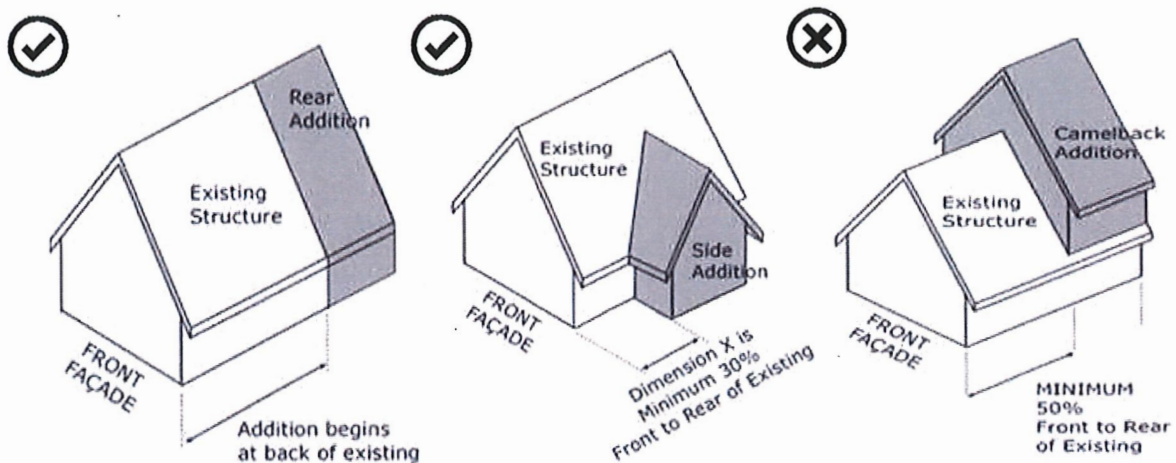

Examples of appropriate and inappropriate additions (Source: City of Houston historic preservation manual)

### **8.3.5 Materials**

The use of building materials for new additions must be carefully considered. The application of high-quality, durable materials that are compatible with the existing primary building is strongly encouraged.

#### **Guidelines**

- Design an addition that is compatible in terms of materials and massing with the exterior form of its primary Contributing building and its setting, yet distinguishable from it. This can be achieved through the use of a different yet compatible cladding material or the use of the same material with a different pattern.
- The application of lower-quality cladding materials or surface coatings (i.e., stucco, vinyl, plastic) is generally discouraged. High-quality, durable materials including brick and stone masonry, wood, fibre cement board and metal is encouraged.
- The application of materials traditionally not found in the District should generally be avoided. Where these materials are located outside of the public realm, they may be permitted.

### 8.4 Secondary Structures on All Properties

Garages, while necessary, are large modern-day additions to residential dwellings. Often, garages consume a large portion of their residential lots and have significant negative impacts on the streetscape. Within the District there are numerous examples of successful garage additions, setback significantly from the front lot line. Some of these additions are connected to the residential dwelling whereas others are erected as stand-alone structures.

#### Guidelines

- Protect and maintain existing secondary structures where they contribute to the heritage value of the property.
- Set new secondary structures back from the principal building façade facing the street.
- The design and massing of secondary structures should be subservient to the primary building(s) on the property.
- New garages can be constructed as standalone structures or connected to residential buildings.
- The scale, massing and materials of new garages shall compliment the existing residential building on the property. Where secondary structures are not visible from the public realm, the use of contemporary materials is permitted.



4354 Line 7 – stand-alone garage structure located at the rear of the property (Source: GDV)



4334 County Rd. 88 – stand-alone garage structure located at the rear of the property (Source: GDV)

#### Locations of Garage Additions

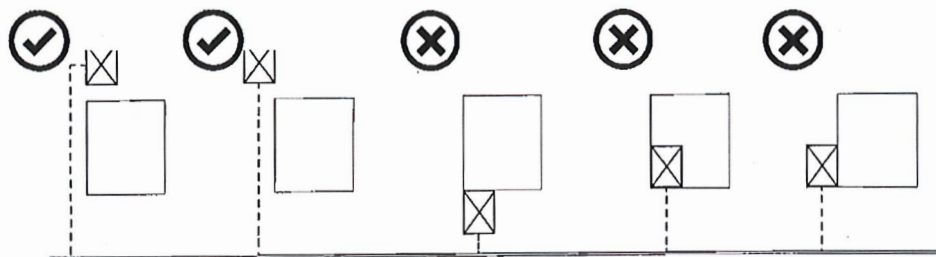

Appropriate and inappropriate locations for new garages from left to right: rear, rear side, front projecting, front flush (Source: Unionville HD Plan)

## 8.5 New Construction

### 8.5.1 General Guidelines

New construction within the District should be sympathetic and subordinate to existing Contributing buildings in their scale, massing, materials and detailing. New construction should not mimic existing Contributing buildings in the District; rather, new buildings should be of their time using design and construction approaches of the present day.

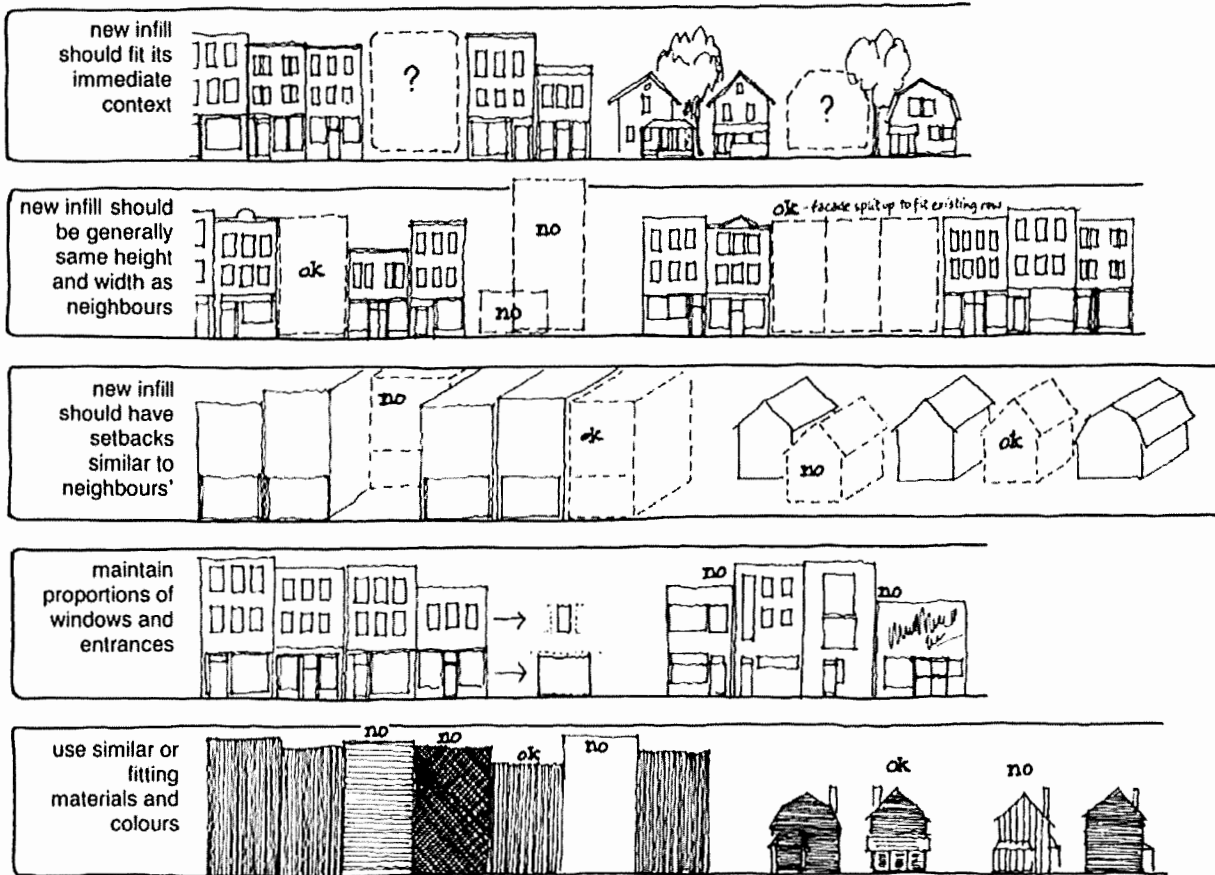

Graphics showing examples of acceptable and unacceptable infill design (Graphic: Ministry of Culture).

### 8.5.2 Scale and Massing

The scale and mass of building additions and new construction must be carefully considered within the District.

#### Guidelines

- New additions to Contributing and supporting buildings to be 1-2 storeys in building height, to be compatible with the low-density scale of the District.
- Small building footprints on large lots are encouraged to provide significant amounts of space between buildings.
- The construction of new buildings shall not obstruct existing viewscales to be maintained within the District.
- Design new buildings so that the proportions, placement, style and materials of windows and doors compliment those of Contributing buildings within the District. This will help to reinforce the village setting and community vision for the District.
- Design new porches, porticoes, verandahs and balconies, so that they compliment the proportions, placement, style and materials of Contributing buildings within the District. This will help to reinforce the village setting and community vision for the District.

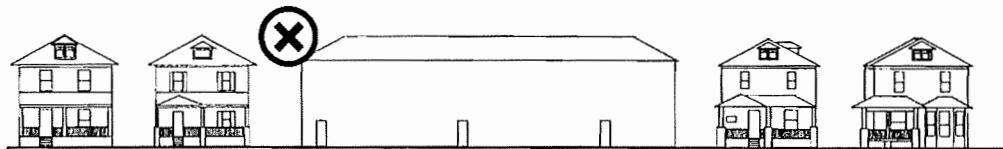

Overall Scale of New Construction (Source: Unionville Heritage District Plan)



Overall Building Form of New Construction (Source: Unionville Heritage District Plan)

### 8.5.3 Building Location and Orientation

The location and orientation of additions and new construction must be carefully considered to ensure the new building ‘fits’ within the existing context of the District.

#### Guidelines

- Design new buildings so that any significant landscape features of the existing property are maintained including mature trees and site topography. Use creative design solutions to integrate new buildings into the existing setting.
- Setback new residential buildings a minimum of 6m back/away from the street to allow sufficient space for sidewalks, front lawns, porches, porticoes and balconies. Deep front yard setbacks are encouraged to emphasize and support the village setting of the District.
- Place new buildings so they are parallel with the street, in concert with existing buildings in the District. The angular placement of buildings, while not common in the District, may be permitted.
- Construct new non-residential buildings within 3-6m from the property line to encourage pedestrian engagement and connectivity along the street.
- The construction of new non-residential buildings is encouraged at the crossroads of the District.
- Buildings on corner sites are encouraged to address all facing streets.

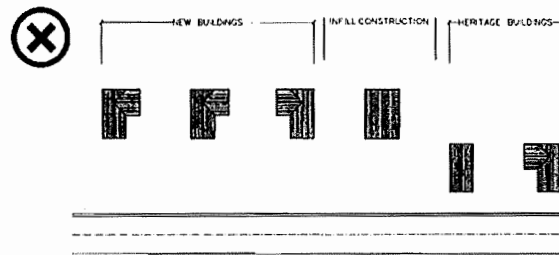

Inappropriate: Setback consistent with new buildings

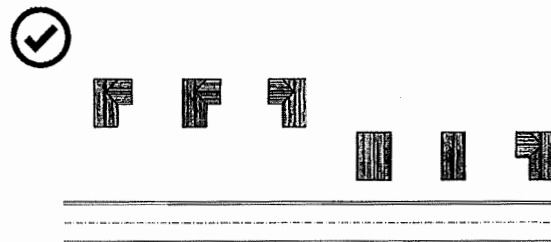

Appropriate: setback consistent with Heritage buildings

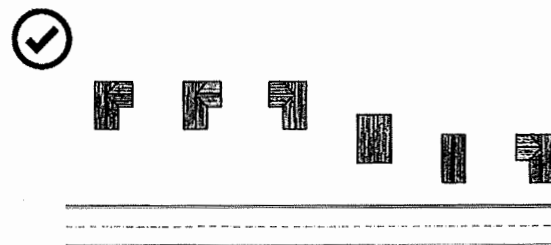

Appropriate: Setback enhances streetscape by mediating between new and old

**Location and Setbacks for New Construction**  
(Source: Unionville HD Plan)

### **8.5.4 Materials**

The use of building materials for new construction in the District must be carefully considered. The application of high-quality, durable materials that are compatible with the surrounding buildings, especially Contributing buildings in the District, is strongly encouraged.

#### **Guidelines**

- Infill construction shall be compatible in terms of materials and massing with the exterior form of surrounding buildings, especially Contributing buildings in the District.
- For new construction, where possible use exterior wall assemblies that compliment existing Contributing buildings. Brick masonry is especially favourable near the crossroads of the village commercial core. Mimicking the details of Contributing buildings within the District is not recommended.
- The application of lower-quality cladding materials or surface coatings (i.e., stucco, vinyl, plastic) is generally discouraged. High-quality, durable materials including brick and stone masonry, wood, fibre cement board and metal is encouraged.
- The application of materials traditionally not found in the District should generally be avoided. Where these materials are located outside of the public realm, they may be permitted.

## **8.6 Demolition**

### **8.6.1 Full and Partial Demolition of Contributing Properties**

These guidelines apply to the full and partial demolition of Contributing properties in the District.

#### **Guidelines**

- The demolition of Contributing buildings in the District is strongly discouraged. Only extenuating circumstances will be considered including structural instability or damage from a catastrophic event, where a qualified structural engineer has determined that the existing building is beyond reasonable repair.
- The Municipality may require a peer review of the structural engineer's report noted above.
- A Heritage Permit for the demolition of a Contributing building in full or in part may not be granted until the design for the replacement building or alterations has been submitted and approved in principle by the Municipality. The design of replacement buildings and alterations must comply with the guidelines for new construction and/or alterations.
- A property owner must be able to demonstrate that all alternative conservation options, including but not limited to preservation, rehabilitation, restoration, reuse, mothballing etc. have been considered and are not feasible for the long-term use of the building.

### 8.6.2 Full and Partial Demolition of Supporting Properties

These guidelines apply to the full and partial demolition of supporting properties in the Heritage Conservation District.

#### Guidelines

- The demolition of supporting buildings in the District is permitted.
- A Heritage Permit for the demolition of a supporting building in full or in part shall not be granted until the design for the replacement building or alterations has been submitted and approved in principle by the Town. The design of replacement buildings and alterations must comply with the guidelines for new construction and/or alterations.

### 8.7 Accessibility

Ease of access to and around buildings should be considered when constructing additions and new buildings. Barrier-free accessibility should be provided to all publicly accessible buildings, as required by IASR (O. Reg. 191/11) of the AODA and adhere to better practice guidelines as recommended by GAATES.

#### Guidelines

- Find solutions to meet accessibility requirements that are compatible with the exterior form of existing building. For example, introducing a gently sloped walkway instead of a constructed ramp with handrails in front of an existing building.
- Work with accessibility, conservation specialists and users to determine the most appropriate solution to accessibility issues with the least impact on character-defining elements and overall heritage values of Contributing building.
- Provide barrier-free entrances for all new non-residential buildings.
- Incorporate barrier-free design solutions into the design of additions and new construction wherever possible, and as required by current codes and by-laws.



*Example of new handrails installed at the main entrance to a heritage building. (Source: GDV)*



*Example of a barrier-free accessible ramp adjacent to a heritage building (Source: Whole Building Design Guide)*

## 8.8 Mechanical/Electrical and Utilities

The positioning of new service fixtures and elements should be carefully considered so as not to detract from the heritage character of the District.

### Guidelines

- Find solutions to incorporate sustainable building initiatives without degrading the heritage value of Contributing buildings.
- Ensure any new solar panels, roof top units, condensers, electrical panels etc. are installed so they are not visible from the public realm.
- Incorporate sustainable design solutions into the design of additions and new construction wherever possible, and as required by current codes and by-laws.

## 8.9 Site Design/Landscaping

Existing landscape features including the existing topography and mature trees are integral to the overall appearance of the District. Wherever possible, the existing topography and mature trees should be maintained as they contribute to the character of the District.

### 8.9.1 Trees and Landscaping/Tree Canopy

Trees and landscaping enhance the village setting and sense of place in the District. Mature trees along County Rd. 27 and County Rd. 88 provide shade and seasonal interest.

### Guidelines

- Protect and maintain mature trees along County Rd. 27 and County Rd. 88, including trees in the public realm and on private property.
- Protect and maintain views and vistas to/from heritage attributes.
- Cutting-back of overgrown trees and shrubs in front of building facades is recommended.
- Plant trees and shrubs to enhance the overall look and feel of properties that are compatible with the scale and massing of existing buildings.
- Limit the amount of hardscaped surfaces and increase the amount of soft landscaping features wherever



2897 County Rd. 27 – existing mature trees along the natural driveway (Source: GDV)



4359 Line 7 – new trees and landscaping shape the property and provide buffering (Source: GDV)

possible. Soft landscaping features include open grassed areas, gardens with flowers and ornamental shrubs, and trees. The inclusion of native and low-maintenance species is encouraged. Native species which have been found historically in the area include Sugar Maple, Red Maple, Silver Maple, White Oak, Red Oak, Hickory and Walnut.



*4280 County Rd. 88 – house sits in a park-like setting with mature trees and sloping side yards (Source: GDV)*

### **8.9.2 Landscape Filters, Fencing and Screening**

Fencing is often erected to demarcate private and public property and/or provide screening and protection. Fencing closes off and isolates space instead of allowing for open connectivity between properties. Fencing is not prevalent within the District. Note: guidelines do not apply to areas outside of public view i.e. residential backyards. However, all fencing must be erected in accordance with the Town's fence by-law.

#### **Guidelines**

- Protect and maintain original fencing where existing.
- Wherever possible, do not erect fencing along the street. Where fencing is erected, provide low-height fencing, designed with maximum transparency.
- Provide new fencing in complementary materials to the building, and the village setting – preferably wood, iron and/or masonry.
- Use historic documentation, where existing, to aid the design of new fencing and landscape filters.
- Consider the use of landscape screening and buffering, such as hedges, in lieu of erecting fencing.



*4370 Line 7 – existing ironwork fencing (Source: GDV)*



*Historic photo of Trinity Anglican Church looking north with wood fencing along the roadway (Source: Bradford Today)*

### 8.9.3 Driveways, Laneways and Walkways

Unpaved driveways of dirt, gravel and vegetation lend to the village setting of the District.

#### Guidelines

- Maintain existing pedestrian paths to front entrances wherever possible.
- Maintain unpaved driveways where possible with compacted dirt and/or gravel.
- Allow one driveway access for each property in the District.
- Locate new driveways in side-yards wherever possible, away from the center of the lot frontage.
- Construct new driveways with natural materials wherever possible. Encourage permeability wherever hard surfaces are installed, including permeable pavers.



4302 County Rd. 88 – existing driveway with natural materials (Source: GDV)



4330 County Rd. 88 – existing driveway with natural materials (Source: GDV)

### 8.9.4 Parking and Access

Parking lots and access to them are necessary for non-residential properties where there is no on-street parking. Wherever possible, parking areas should be located to the rear of buildings and properties. Buffering via landscaping and vegetation is encouraged.

#### Guidelines

- Protect and maintain original access routes and parking areas wherever possible.
- Maintain unpaved driveways where possible with compacted dirt and/or gravel.
- Ensure access pathways are stable and smooth.
- Limit the amount of new hard surface treatments to driveways, parking areas and sidewalks. Encourage



4240 County Rd. 88 – outdoor pathways (Source: GDV)

permeability wherever hard surfaces are installed, including permeable pavers.

- Buffer parking areas with landscaping and vegetation wherever possible.
- Locate new surface parking to the rear of buildings or in side yards. Surface parking in front yards is discouraged.
- Allow one driveway access for each property in the District.
- Every owner or operator of a public parking area shall provide accessible parking spaces in conformity with the provisions of the Town of BWG's prevailing Accessible Parking By-laws.



4240 County Rd. 88 – parking and access (Source: GDV)

### 8.10 Lot Severance and Assembly

Consent applications will be evaluated on a case-by-case basis for lot severances and assembly in the District. All severances must conform to provincial and local policies and by-laws including but not limited to in-effect *Official Plan* and Zoning by-law. In addition, within the Bond Head Heritage Conservation District, severances may be possible, however, the lot size of any infill property or severance shall reflect the character of the surrounding lot fabric.

## 8.11 General Maintenance

Routine monitoring and general maintenance are required to ensure buildings, and their heritage attributes do not fall into a state of disrepair.

### Guidelines (Minimum Requirement):

- All general maintenance should be performed with attention to the Township of Bradford West Gwillimbury's Property Standards By-law which provides minimum maintenance standards for properties in the District.

### Best Practice:

- Determine the cause of any distress, damage or deterioration through investigation, monitoring and minimally invasive testing techniques. Address signs of distress, damage and deterioration as soon as possible.
- Protect and maintain exterior walls by cleaning and repairing damaged materials, and checking for moisture penetration and insect infestation, taking corrective action, as necessary and as soon as possible.
- Clean masonry buildings to halt deterioration and remove heavy soiling. When cleaning masonry on Contributing buildings, use recognized conservation practices. In areas of heavy staining or surface deposits of dirt, vegetation or bird guano, perform masonry cleaning tests prior to proceeding with the work. Clean masonry with low pressure washes, limiting the amount of water and pressure being applied to the surfaces of exterior walls. Refrain from using washes and detergents with chemicals. Maintaining the natural patina of the masonry is encouraged.
- Stabilize exterior walls by using structural reinforcement, weather protection, or correcting unsafe conditions, as required, until repair work is undertaken.



*Example of heritage masonry façade prior to cleaning (Source: GDV)*

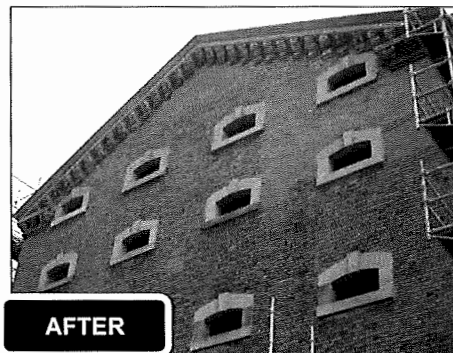

*Example of heritage masonry façade after warm water wash and JOS system application (Source: GDV)*

- Protect and maintain windows by using appropriate surface treatments, such as cleaning, rust removal, limited paint removal, and reapplying protective coating systems in kind.
- Protect and maintain doors and entrances by using appropriate surface treatments, such as cleaning, rust removal, limited paint removal, and reapplying protective coating systems in kind.
- Protect and maintain a roof by cleaning and maintaining the gutters, downspouts and flat roof drains, and replacing deteriorated flashing in kind.

## 8.12 Public Realm

### 8.12.1 Building Design and Interface

Buildings in the public realm, including the Bond Head Community Centre, contribute to the village character of the District. These buildings should be maintained wherever possible.

#### Guidelines

- Protect and maintain public open spaces, and significant open space between buildings.
- Protect and maintain existing Contributing buildings in the public realm wherever possible.
- Alterations to Contributing and supporting buildings in the public realm shall follow the design guidelines included in the HCD Plan.
- New construction in the public realm shall follow the design guidelines included in the HCD Plan and incorporate barrier-free design solutions as per AODA Standards



2892 County Rd. 27 - Bond Head Community Memorial Hall (Source: GDV)



2892 County Rd. 27 – Bud Brown Memorial Park (Source: GDV)

### 8.12.2 Streetscapes

#### 8.12.2.1 Sidewalks

Sidewalks contribute to walkable of the District and provide a safe space for pedestrians in the public realm.

#### Guidelines

- Protect and maintain existing circulation paths wherever possible.
- Encourage the construction of sidewalks for a walkable village setting. Introduce curbed bump-outs and parking lay-bys where possible to widen the area of pedestrian foot traffic. Ensure sidewalks are stable, smooth and continuous throughout the District.
- Construct sidewalks to meet current accessibility guidelines.



Looking east along the north side of County Rd. 88 (Source: GDV)

### 8.12.2.2 **Parking and Access**

Parking lots and access to them are necessary for non-residential properties, especially where there is no on-street parking. Wherever possible, parking areas should be located to the rear of buildings and properties. Buffering via landscaping and vegetation is strongly encouraged.

#### **Guidelines**

- Protect and maintain original access routes and parking areas wherever possible.
- Maintain unpaved driveways where possible with compacted dirt and/or gravel.
- Limit the amount of new hard surface treatments to driveways, parking areas and sidewalks. Encourage permeability wherever hard surfaces are installed, including permeable pavers and brick/cobblestone surfacing as accents or borders



2892 County Rd. 27 – Parking for Bud Brown Memorial Park (Source: GDV)

- Buffer parking areas with landscaping and vegetation wherever possible.
- Locate new surface parking to the rear of buildings or in side yards. Surface parking in front yards is discouraged.

### 8.12.2.3 **Street Furniture**

Street furniture contributes to the village character of the District. Street furniture act as nodes where pedestrians pause, rest and gather along sidewalks and paths. The quality and condition of street furniture is important to maintaining a positive visual image in the District.

#### **Guidelines**

- Protect and maintain existing street furniture including but not limited to bench seating, bike racks, planters and flag poles.
- Repair and/or replace existing street furniture when deteriorated and/or damaged.
- Where new street furniture is installed, ensure the furniture is functional, of high quality, consistent throughout the District and that it reflects the heritage character of the village setting.



Existing street furniture at Audrey Wychopen Memorial Parkette (Source: GDV)

- The installation of private street furniture including but not limited to bench seating, bike racks and planters is encouraged. Private street furniture shall also reflect the heritage character of the village.

### 8.12.2.4 Lighting

Lighting in the public realm is essential for illuminating streets, sidewalks and buildings. Light posts can also compliment the character of the District and facilitate the installation of flowerpots, banners and signage.

#### Guidelines

- Maintain the existing heritage-style lighting at the crossroads of the District.
- Ensure street lighting is provided at regular intervals along the streetscape.
- The addition of more street lighting in the District is encouraged.
- When new street lighting is installed, ensure it is consistent throughout the District to reflect the heritage character of the village setting.



Existing Lighting at Crossroads of HCD  
(Source: GDV)

### 8.12.2.5 Gateways and Signage

Signage within the public realm consists of street signage, wayfinding, commemorations and memoriam. The introduction of interpretive signage can also provide historic, site specific information and images of a place for the general public to view and experience.

#### Guidelines

- Protect and maintain stone gateway with plaques at the entrance to Bud Brown Park.
- Protect and maintain existing street and wayfinding signage throughout the District.
- Introduce new gateway signage at the limits of the Heritage Conservation District along County Rd. 27, Line 7 and County Rd. 88.
- When existing street and wayfinding signage requires replacement, design new street and wayfinding signage to reflect the heritage character of the village.

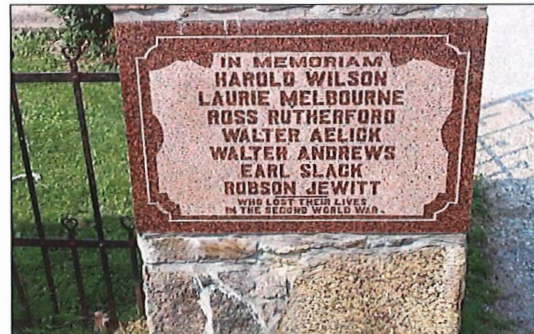

2892 County Rd. 27 - Gateway Memorial Plaque

- New street signage to be consistent throughout the District and reflect the heritage character of the District.
- The addition of new wayfinding and interpretive signage is encouraged to inform visitors of the history of Bond Head.

### 8.12.2.6 *Trees and Plantings*

Street trees and plantings help to soften the visual impact of asphalt, concrete and infrastructure and are essential to maintaining the village character of Bond Head.

#### **Guidelines**

- Protect and maintain mature trees in the public realm wherever possible.
- Protect and maintain views and vistas to/from heritage attributes.
- Cutting-back of overgrown trees and shrubs in front of building facades is recommended.
- Plant trees and shrubs to enhance the overall look and feel of the public realm and that are compatible with the scale and massing of existing buildings and streetscape features.
- Avoid removing street trees and plantings unless they present a safety hazard or are in decline due to age or disease. Where tree removal is required, replace in kind with appropriate native species that reflect the existing character of the District in coordination with the Town.
- Limit the amount of hardscaped surfaces and increase the amount of soft landscaping features wherever possible. Soft landscaping features include open grassed areas, gardens with flowers and ornamental shrubs, and trees, and planters. The inclusion of native and low-maintenance species is encouraged. Native species which have been found historically in the area include Sugar Maple, Red Maple, Silver Maple, White Oak, Red Oak, Hickory and Walnut.



*Plaque for The Old Plank Road with plantings  
(Source: GDV)*



*View of mature trees around Bud Brown Memorial  
Park (Source: GDV)*

### **8.12.3 Parks and Open Spaces**

Parks and open spaces are important communal areas for people to gather in the District. Parks contribute to the character of the District and should be protected and maintained wherever possible.

#### **Guidelines**

- Protect and maintain existing parks and open spaces.
- Protect and maintain mature trees around Bud Brown Memorial Park.
- Provide sufficient lighting for all parks and pathways.
- Encourage the placement of new street furniture, vegetation and public art.

## 9.0 IMPLEMENTATION OF THE HCD PLAN

### 9.1 Heritage Permit Process

#### WHAT IS A HERITAGE PERMIT?

A heritage permit is issued by the Town and only required when certain alterations are proposed. Heritage Permits may be required for changes which directly impact or affect the cultural heritage value and/or the heritage attributes of the individual properties or the District as a whole.

A heritage permit system allows the Town to:

- Monitor the conservation of the District;
- Guide and manage changes within the District;
- Ensure any new or proposed work is in keeping with the Objectives, Policies and Guidelines of the District Plan.

A heritage permit is required prior to any work that may result in, or is has the potential to result in, the alteration, obstruction, removal or damage to one or more of the heritage attributes of a property under the *Ontario Heritage Act*.

#### WHEN IS A HERITAGE PERMIT REQUIRED?

Prior to commencing any work, the property owner proponent who is proposing work within the District boundary should contact the Town to determine if a heritage permit is required. The Town will work with the proponent to help them in navigating the heritage application process as needed and aid with any development approvals which may be required for the proposed work.

Interior alterations are not subject to the heritage permitting process.

The heritage permitting process is intended to reflect a flexible approach when it comes to maintenance and/or minor changes to existing properties, and a more rigorous review for larger and more substantial changes. Overall, the category of the types of alterations falls into one of three categories within the District:

#### *EXEMPT*

Work that is exempt and does not require a heritage permit includes regular maintenance, repairs, and changes which are considered routine in nature. Exemptions for replacement of some features with like materials may also fall within this category. For example, replacement of a shingle roof with a shingle roof is exempt from the permitting process as long as the style, pitch of the roof is unchanged.

#### *MINOR*

A heritage permit may be required when small to medium changes to a property are proposed. If the proposed minor work is deemed to be in keeping with the Objective, Policies and Guidelines of District Plan, then the Town, by way of delegated authority, can approve the work without any additional consultation as a means to streamline the process.

If the Town determines that the proposed work requires additional consideration or study, the proposed alteration will be reviewed by a subcommittee which has been specifically established to review heritage permits or the Heritage Committee will be consulted and a determination made.

*MAJOR*

When significant changes or modifications are proposed which will have, or has the potential to have, major impacts on the cultural heritage value of the District and/or the heritage attributes of the property as described in the Statement of Contributions, a heritage permit is required. Major heritage permits require Council approval.

The following table provides more details about which are considered Exempt, Minor, or Major in nature.

**Table 2: Heritage Permit Requirements- Contributing Buildings**

	Categories of Alteration		
	Major	Minor	Exempt
<b>Repair and Routine Maintenance</b>			
Routine repairs or maintenance efforts on exterior building features which uses an in-kind approach for materials, profile, and finishes including: <ul style="list-style-type: none"> <li>• roof shingles or cladding</li> <li>• roofing or flashing</li> <li>• wall cladding</li> <li>• windows, sills, lintels and/or window surrounds</li> <li>• doors, transoms sidelights, and/or door surrounds</li> <li>• shutters, or shutter hardware</li> <li>• dormers</li> <li>• chimneys</li> <li>• decorative wood elements including trim or newels</li> <li>• decorative brackets on roof or porch</li> <li>• eaves, soffits, fascia</li> <li>• cornices, frieze, architrave</li> <li>• columns</li> <li>• balustrades</li> <li>• porches, patios, balconies or verandahs</li> <li>• pathways and steps</li> <li>• eavestroughs and downspouts</li> </ul>			✓
Weatherproofing, including caulking, and insulating			✓
Repainting or Painting exterior elements (colour)			✓
Structural repairs which do not impact the structural integrity of the building or the exterior which is visible from the streetscape			✓
<b>Alterations</b>			
Alteration or replacement of a heritage attribute/s listed in the statement of contribution including but not limited to: <ul style="list-style-type: none"> <li>• Window openings</li> <li>• Window surrounds</li> <li>• Door openings</li> <li>• Transoms and sidelights</li> <li>• Brackets</li> <li>• Wall cladding and cladding details noted</li> <li>• Roof style</li> <li>• Height</li> <li>• Number of Bays</li> <li>• balconies, verandahs, porches</li> <li>• Any other decorative features listed in the Statement of Contribution</li> </ul>	✓		

	Categories of Alteration		
	Major	Minor	Exempt
While strongly encouraged to be maintained and retained, alterations to, removal of, or replacement elements which are not listed in the statement of contribution including but not limited to: <ul style="list-style-type: none"> <li>• window hardware</li> <li>• doors</li> <li>• door hardware</li> <li>• sills and lintels</li> <li>• shutters</li> <li>• dormers</li> <li>• chimneys</li> <li>• decorative wood</li> <li>• brackets</li> <li>• eaves</li> <li>• soffits</li> <li>• fascia</li> <li>• cornices</li> <li>• columns</li> <li>• balustrades</li> <li>• balconies, verandahs, porches, patios</li> </ul>			✓
Interior renovations or works which do not affect the exterior			✓
Alteration to, or replacement of, exterior elements which are not visible from the Street			✓
Painting exterior cladding (i.e., brick, stone) if listed as heritage attribute	✓		
<b>Relocation and Demolition</b>			
Relocation or Demolition of a Contributing Building	✓		
Demolition of an outbuilding (i.e., garage or shed)			✓
<b>Additions and New Construction</b>			
Construction of a new building on a Contributing lot	✓		
Construction of an outbuilding (i.e., garage or shed)		✓	
Side or front addition on building which is visible from street	✓		
Rear addition		✓	
Addition of porches, verandas, dormers, additional window and/or door openings etc. on front or side of building which is visible from Street	✓		
Addition or alteration of signage		✓	
<b>Landscaping</b>			
Expansion of an existing driveway		✓	
Installation of utilities (i.e., gas meter, smart meters, water meters)			✓
Change to the location or size of parking areas		✓	
Installation of a hot tub, pool, sauna, greenhouse etc. which is not visible from the Street			✓

	Categories of Alteration		
	Major	Minor	Exempt
Installation of a hot tub, pool, sauna, greenhouse etc. which is visible from the Street		✓	
Front soft landscaping			✓
Rear soft landscaping			✓
Construction of fencing at front or side of property		✓	
Construction of fence at rear of property			✓

**Table 3: Heritage Permit Requirements- Supporting Buildings**

	Categories of Alteration		
	Major	Minor	Exempt
<b>Repair and Routine Maintenance</b>			
<p>Routine repairs or maintenance efforts on exterior building features which use an in-kind approach for materials, profile, and finishes including:</p> <ul style="list-style-type: none"> <li>• roof shingles or cladding</li> <li>• roofing or flashing</li> <li>• wall cladding</li> <li>• windows, sills, lintels and/or window surrounds</li> <li>• doors, transoms sidelights, and/or door surrounds</li> <li>• shutters, or shutter hardware</li> <li>• dormers</li> <li>• chimneys</li> <li>• decorative wood elements including trim or newels</li> <li>• decorative brackets on roof or porch</li> <li>• eaves, soffits, fascia</li> <li>• cornices, frieze, architrave</li> <li>• columns</li> <li>• balustrades</li> <li>• porches, patios, balconies or verandahs</li> <li>• pathways and steps</li> <li>• eavestroughs and downspouts</li> </ul>			✓
Weatherproofing, including caulking, and insulating.			✓
Repainting or Painting exterior elements (colour)			✓
Structural Repairs which do not impact the structural integrity of the building or the exterior which is visible from the streetscape			✓

	Categories of Alteration		
	Major	Minor	Exempt
<b>Alterations</b>			
Alteration to, removal of, or replacement of any exterior element, including but not limited to: <ul style="list-style-type: none"> <li>• Windows</li> <li>• Doors</li> <li>• Transoms and sidelights</li> <li>• Brackets</li> <li>• Wall cladding and cladding details noted</li> <li>• Roof style</li> <li>• Height</li> <li>• Number of Bays</li> <li>• Existing driveway</li> <li>• balconies, verandahs porches</li> <li>• Any other exterior element</li> </ul>			✓
Alteration of signage		✓	
Interior renovations or works which do not impact the exterior			✓
Painting exterior cladding			✓
<b>Relocation and Demolition</b>			
Relocation of Demolition of a Supporting Building	✓		
Demolition of an outbuilding (i.e., garage, shed)			✓
<b>Additions and New Construction</b>			
Construction of a new building on a Supporting lot	✓		
Construction of an outbuilding (i.e., garage or shed)		✓	
Side or front addition on building which is visible from street		✓	
Rear addition			✓
Addition of porches, verandas, dormers, additional window and/or door openings etc. on front or side of building which is visible from Street		✓	
Addition or alteration of signage		✓	
<b>Landscaping</b>			
Expansion of an existing driveway		✓	
Installation of utilities (i.e., gas meter, smart meters, water meters)			✓
Change to the location or size of parking areas		✓	
Installation of a hot tub, pool, sauna, greenhouse etc. which is not visible from the Street			✓
Installation of a hot tub, pool, sauna, greenhouse etc. which is visible from the Street		✓	
Front soft landscaping			✓
Rear soft landscaping			✓
Construction of fencing front of property		✓	
Construction of fence rear of property			✓

## HOW DOES THE HERITAGE PERMIT PROCESS WORK?

Figure 1 outlines the typical steps taken when there are proposed alterations, additions, and other works to properties and buildings within the District, based on the recommendation that Town Planning staff be provided delegated authority to make decisions on applications independently and/or in consultation with a District heritage permit review body.

Figure 1: Heritage Permit Review Process

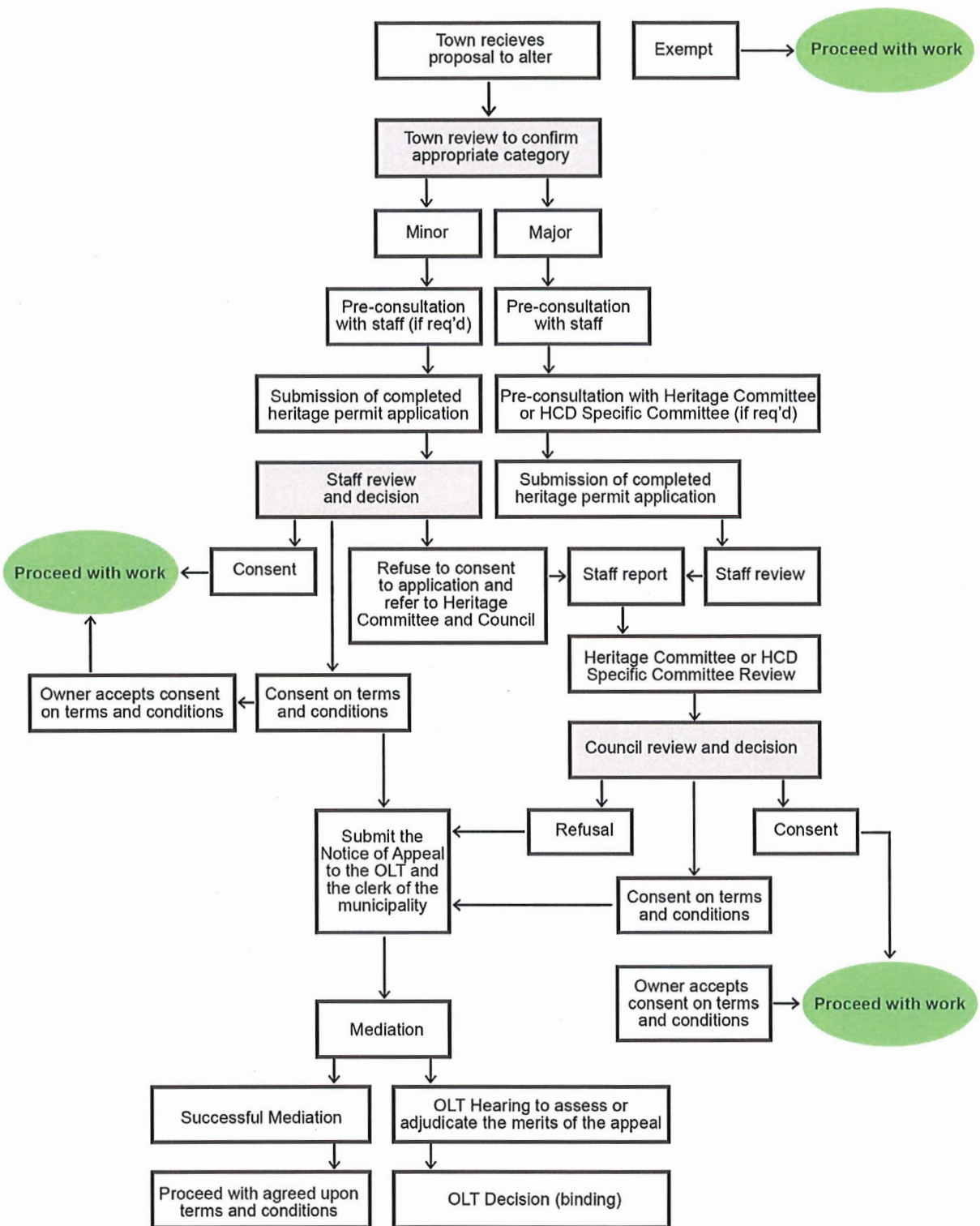

## 9.2 Integration of the District Plan

Once the District by-law comes into force, various administrative and policy-based measures will be required to be created and/or integrated into large planning frameworks for the successful implementation of the District Plan. It includes but is not limited to:

- A permit application review process that is simple, efficient, and fair.
- Delegated authority to planning staff to approve minor heritage permits shall be integrated into planning frameworks.
- A review body can be established with property owners from the District who can provide advice to applicants and the Town on proposed alterations, new construction and demolitions within the District. Similarly, a representative from the District should be a member of the Heritage Committee.
- A Heritage Impact Assessment Terms of Reference should be established to ensure any changes are in compliance with the District Plan.
- Easy to follow and readily available information and assistance to help applicants in preparing proposals and applications.
- The Plan should be periodically reviewed and updated if necessary.

Additional Administrative options to further support and promote the District and good stewardship include:

- Update the Heritage Property Tax Rebate Program to benefit Contributing Properties.
- Continuing public awareness activities to promote the District Concept, the Boundary, and the Policies and Guidelines of the District Plan
- If there is a community desire, a Heritage Property Standard By-Law may be considered, which is in keeping with the objective and policies outlined in this Plan.

## 9.3 Grants and Incentives

The Town currently has an active heritage property tax relief program. The *Municipal Act* (2001) allows municipalities to enact a heritage property tax relief program for properties designated under Part IV and Part V of the *Ontario Heritage Act*. Municipalities can set the amount of tax relief they wish to offer (between 10 per cent and 40 per cent) and develop eligibility criteria in addition to those prescribed in the legislation. The Town offers an annual property tax reduction of up to 40% (including the municipal, county and provincial/school board components).

To be eligible for the Town's Heritage Tax Rebate Program the following criteria would need to be satisfied:

1. The subject property must be designated under Part IV of the *Ontario Heritage Act* and/or part of a Heritage Conservation District designated under Part V of the *Ontario Heritage Act* and have been identified as a *Contributing building*;
  - To gain 'heritage designation' a designation by-law must be passed by Council. For reference, to be designated means the property has formally been recognized by the municipality as culturally important, has heritage value and is worthy of on-going care. Within the by-law heritage attributes and other character defining elements are itemized and described.
- Within the by-law attributes fall within the categories of design/physical, contextual/natural heritage and historical/associative These 'specifically' identified

attributes are protected from un-sympathetic alteration and demolition. The property owner would be required to enter into Heritage Conservation Agreement with the Town;

- A Heritage Conservation Agreement is a legal agreement between the Town and property owner to protect and maintain the heritage features of a property, and to encourage good stewardship of the property. By signing the Agreement, the owner of a designated property would agree to maintaining the state of the identified heritage attributes beginning in the first year in which the owner applies for a tax rebate and the obligation to maintain would continue thereafter. This agreement would be binding upon the Owner, its successors in title, heirs and assigns and the provisions thereof would run with the land.
- The agreements may have site specific requirements; however, the typical agreement would require the owner to
  - (1) maintain the property in good condition,
  - (2) seek approval for alterations that may affect its heritage attributes or features, and
  - (3) provisions for the municipality to monitor the condition of the property periodically.
- Any residential building(s) must be habitable and should be occupied.
- The Owner must provide an insurance certificate from an insurance company/agent/broker that states that the Owner has a valid insurance policy which insures the building(s) against normal perils that are coverable by all risk property insurance in an amount equal to the replacement cost of a similar scaled new building(s) with an exterior design complementary to the existing structure(s).
- The property must not be subject of any Town by-law contraventions, work orders, penalties, fees, and arrears of taxes, fines or other outstanding municipal requirements as of the date of application.
- Submission of a 'complete application' on annual basis.

The loss of heritage properties due to simple neglect is an avoidable tragedy and small levels of assistance have proven to be very effective in encouraging needed repairs and restoration.

## 10.0 GLOSSARY AND TERMS

**Accessibility:** The degree to which an historic place is easy to access by as many people as possible, including people with disabilities (S&G 2010:253).

**Adjacent:** d) for the purposes of policy 4.6.3, those lands contiguous to a protected heritage property or as otherwise defined in the municipal official plan. (PPS 2024: 38).

**Alteration:** to change in any manner and includes to restore, renovate, repair or disturb (OHA).

**Balustrade:** A railing system, generally around a balcony or on a second level, consisting of balusters and a top rail (Kyles 2022).

**Bay Window:** A window that projects out from a wall, in a semicircular, rectangular, or polygonal design. Used frequently in Gothic and Victorian designs (Kyles 2022).

**Built heritage resource (BHR):** means a building, structure, monument, installation or any manufactured or constructed part or remnant that contributes to a property's cultural heritage value or interest as identified by a community, including an Indigenous community (PPS 2024:41).

**Bargeboard:** Originally known as vergeboard. It is term for the decorative wooden edging on Gothic Revival and Victorian houses. Boards or other decorative woodwork fixed to the edges or projecting rafters of a gabled roof. Sometimes called gingerbread (Kyles 2022).

**Banding:** Different materials, colours or textures used in horizontal bands along a wall.

**Bracket:** An ornamental projection from the face of a wall providing visual or structural support for a statue, cornice, balcony, or window (Kyles 2022).

**Chimney:** The stone, metal or masonry of a fireplace that extends up from the fireplace through the roof and carries the smoke outside. Chimneys can be either brick or stone. They can be wood with stucco and metal as well (Kyles 2022).

**Conserved** means the identification, protection, management and use of built heritage resources, cultural heritage landscapes and archaeological resources in a manner that ensures their cultural heritage value or interest is retained. This may be achieved by the implementation of recommendations set out in a conservation plan, archaeological assessment, and/or heritage impact assessment that has been approved, accepted or adopted by the relevant planning authority and/or decision-maker. Mitigative measures and/or alternative development approaches should be included in these plans and assessments (PPS 2024:41).

**Contributing properties** demonstrate one or more of the key attributes or values that individually or in combination with the public realm reflect the distinct character of the District. Contributing properties exhibit physical heritage attributes which directly contribute to the cultural heritage value or interest of the District in their design or physical value, historical or associative value, or contextual value.

**Cornice:** Originally this element was the wooden overhang of the roof. Translated to stone, brick, iron, and steel, it became any projecting shelf at the top of a ceiling, roof, or pediment. These can be highly decorated (Kyles 2022).

**Cultural Heritage Value or Interest (CHVI)**, also referred to as Heritage Value within a Heritage Conservation District, is identified if a property meets two or more of the criteria outlined in O. Reg. 569/22.

**Development** means the creation of a new lot, a change in land use, or the construction of buildings and structures, requiring approval under the *Planning Act*, but does not include:

- a) activities that create or maintain infrastructure authorized under an environmental assessment process; or
- b) works subject to the Drainage Act (Simcoe County OP 2022:125).

**Dichromatic Brickwork:** Two or more colours of brick have been used to decorate public and private buildings (Kyles 2022).

**Door surround:** A door surround is any moulding, opening or embellishment around a door or door opening. This is a key indicator of the style of the building. Door surrounds can have pediments, slays, and cornices, but always have jambs, reveals, and casings (Kyles 2022).

**Dormer:** A window that pierces through, or project from, the sloping roof, usually to that of a bedroom area (Adapted from Kyles 2022).

**Façade:** The "face" of a building, usually the front. To be a façade as opposed to simply an elevation, the building must have been designed with a particular style and incorporate design elements such as an impressive entrance or window surrounds. The arrangement of windows on a facade is called fenestration (Kyles 2022)

**Finial:** Any ornament added to the top of a gable, pinnacle, canopy, or spire. These are a Gothic element (Kyles 2022)

**Frieze:** A continuous horizontal band of carved or painted decoration. It was originally the middle band of an entablature which lies between the architrave and the cornice.

**Gable:** The triangular end of a roof above the eaves which closes the roof on that end. Also, the triangular end of a dormer or a triangular cut in a roof for a window or door. The slope of the gable end depends on the slope of the roof. For Gothic designs the slope tends to be acute; for Classical buildings the slope is gentler (Kyles 2022).

**Heritage Attribute:** In relation to real property, and to the building and structure on the real property, the attributes of the property, buildings and structures that contribute to their cultural heritage value or interest (OHA).

**Heritage attributes:** means, as defined under the Ontario Heritage Act, in relation to real property, and to the buildings and structures on the real property, the attributes of the property, buildings and structures that contribute to their cultural heritage value or interest (PPS 2024:44)

**Heritage Impact Assessment:** A study undertaken to assess the impacts of a proposed development or site alteration against the identified cultural heritage value or interest and heritage attributes of a protected heritage resource, or a property located within a Heritage Conservation District. The scope of a Heritage Impact Assessment is determined in consultation with the Town. The Heritage Impact Assessment considers alternative development approaches or mitigation measures to address any impacts to a cultural heritage resource and its attributes. A Heritage

Impact Assessment may be required where construction, alteration, demolition, or additions to a property located within a Heritage Conservation District.

**Hipped roof:** A roof that slopes on four sides.

**In situ:** This term means 'in place' and as used in this document, it refers to the action of protecting, maintaining and/or stabilizing the existing materials in the location where they were found (S&G 2010:254)

**In kind:** with the same form, material, and detailing as the existing. (S&G 2010:254)

**Individual Designation:** Means real property designated under Part IV of the Ontario Heritage Act by municipal by-law. The designation by-law should include an adequate description of the property, a statement explaining the cultural heritage value or interest of the property and a description of the heritage attributes of the property (Section 29(4) of the *Ontario Heritage Act*)

**Lintel:** The horizontal architectural member - stone, wood or metal - that spans an opening and supports the weight above it (Kyles 2022).

**Maintenance:** Routine, cyclical, non-destructive actions necessary to slow the deterioration of a historic place. It entails periodic inspection; routine, cyclical, non-destructive cleaning; minor repair and refinishing operations; replacement of damaged or deteriorated materials that are impractical to save (S&G 2010: 254).

**Minimal intervention:** The approach that allows functional goals to be met with the least physical intervention (S&G 2010:254).

**Quoin (quoining):** A stone forming the external corner of a wall. Quoins are a decorative element and are generally larger or of a different colour than the rest of the wall (Kyles 2022).

**Restoration:** The action or process of accurately revealing, recovering or representing the state of a historic place or of an individual component, as it appeared at a particular period in its history, while protecting its heritage value (S&G 2010:255).

**Rehabilitation:** The action or process of making possible a continuing or compatible contemporary use of a historic place or an individual component, while protecting its heritage value (S&G 2010:255).

**Roof:** The structure that covers the top of a building (Kyles 2022).

**Sidelight:** A window beside a door, forming part of the door unit (Kyles 2022).

**Signage:** The identifier on buildings - the signs. These can be both private and public and advertise what the purpose of the building is (Kyles 2022).

**Significant:** e) in regard to cultural heritage and archaeology, resources that have been determined to have cultural heritage value or interest. Processes and criteria for determining cultural heritage value or interest are established by the Province under the authority of the Ontario Heritage Act. (PPS 2024:52).

**Soffit:** The underside of a roof overhang, portico, beam, or arch. It can also be the underside of a drain or sewer. These can be plain or very ornate (Kyles 2022).

**Owner:** means the person registered on title in the proper land registry office as owner (OHA).

**Protected Heritage Property** means property designated under Parts IV, V or VI of the *Ontario Heritage Act*; property subject to a heritage conservation easement under Parts II or IV of the *Ontario Heritage Act*; property identified by the Province and prescribed public bodies as provincial heritage property under the *Standards and Guidelines for Conservation of Provincial Heritage Properties*; property protected under federal legislation, and UNESCO World Heritage Sites (Simcoe OP 2016:133).

**Vernacular:** Indigenous, made locally by inhabitants; made using local materials and traditional methods of construction and ornament; specific to a region or location (S&G 2010:256).

## 11.0 BIBLIOGRAPHY AND SOURCES

### County of Simcoe

- 2021 *The Corporation of the County of Simcoe By-law No.6894*. Forest Conservation By-law accessed online at:  
<https://www.simcoe.ca/Forestry/Documents/Forest%20Conservation%20By-law%20No.%206894.pdf>
- 2016 *County of Simcoe Official Plan*. Accessed online at:  
<https://www.simcoe.ca/Planning/Documents/SimcoeOfficialPlanText.pdf>.

### Government of Ontario

- 2021 *Ontario Heritage Act*, R.S.O. 1990, c. O.18. Accessed online at:  
<https://www.ontario.ca/laws/statute/90o18>.
- 2022 *Ontario Regulation 569/22 made under the Ontario Heritage Act*. Accessed online at:  
<https://www.ontario.ca/laws/regulation/r22569>

### Legislative Assembly of Ontario (LOA)

- 2019 *Bill 108, More Homes, More Choice Act, 2019*. Accessed online at:  
[www.ola.org/en/legislative-business/bills/parliament-42/session-1/bill-108/status](http://www.ola.org/en/legislative-business/bills/parliament-42/session-1/bill-108/status).

### Ministry of Citizenship and Multiculturalism (MCM)

- 2006a *Heritage Conservation Districts: A Guide to District Designation under the Ontario Heritage Act*. Ontario Heritage Tool Kit Series. Toronto: Ministry of Culture.
- 2006b *Heritage Resources in the Land Use Planning Process*. Ontario Heritage Tool Kit Series. Toronto: Ministry of Culture.

### Ministry of Municipal Affairs and Housing (MMAH)

- 2024 *Provincial Planning Statement, 2024*. Toronto: Ministry of Municipal Affairs and Housing.
- 2018 *Citizen's Guide – Official Plans 2 (In a Series)*. Toronto: Ministry of Municipal Affairs and Housing.

### Ontario Heritage Trust

- 2019a *Heritage Conservation Districts*. Accessed online at: [www.heritagetrust.on.ca/en/pages/tools/conservation-districts](http://www.heritagetrust.on.ca/en/pages/tools/conservation-districts).
- 2019b *Architectural Style*. Places of Worship Database. Accessed online at:  
[www.heritagetrust.on.ca/en/places-of-worship/places-of-worship-database/architecture/architectural-style](http://www.heritagetrust.on.ca/en/places-of-worship/places-of-worship-database/architecture/architectural-style).
- 2018a *Easement properties*. Accessed online at: [www.heritagetrust.on.ca/en/index.php/property-types/easement-properties](http://www.heritagetrust.on.ca/en/index.php/property-types/easement-properties)

### Parks Canada

- 2010 *Standards and Guidelines for the Conservation of Historic Places in Canada: A Federal, Provincial and Territorial Collaboration*, 2nd edition. Queen's Printer for Canada. Accessed online at: [www.historicplaces.ca/media/18072/81468-parks-s+g-eng-web2.pdf](http://www.historicplaces.ca/media/18072/81468-parks-s+g-eng-web2.pdf).
- 1950 'Osler, Sir William' in *Directory of Federal Heritage Designations*. Accessed online at:  
[https://www.pc.gc.ca/apps/dfhd/page\\_nhs\\_eng.aspx?id=1416](https://www.pc.gc.ca/apps/dfhd/page_nhs_eng.aspx?id=1416)
- 2018b *Resources – Ontario Heritage Act*. Accessed online at:  
[www.heritagetrust.on.ca/en/index.php/.../ontario-heritage-conservation.../resource](http://www.heritagetrust.on.ca/en/index.php/.../ontario-heritage-conservation.../resource).

### Town of Bradford West Gwillimbury (BWG)

- 2021 *The Corporation of the Town of Bradford West Gwillimbury By-law 2020-40. Building By-law* accessed online at:  
<https://bradfordwestgwillimbury.civicweb.net/filepro/documents/?preview=25659>
- 2021 *The Corporation of the Town of Bradford West Gwillimbury By-law 2020-105. Fence By-law* accessed online at:  
<https://bradfordwestgwillimbury.civicweb.net/filepro/documents/?preview=33249>
- 2021 *Town of Bradford West Gwillimbury Official Plan. Accessed online at:*  
<https://www.townofbwg.com/Docs/Services/Planning/BWG-OP-Final-Council-Adopted-Mar-2021.pdf>.
- 2017d *The Corporation of the Town of Bradford West Gwillimbury By-law 2017-33. Fill and Site Alteration By-law* accessed online at:  
<https://bradfordwestgwillimbury.civicweb.net/filepro/documents/?preview=31941>
- 2017e *The Corporation of the Town of Bradford West Gwillimbury By-law 2017-78. Entrance and Driveway Width Extension By-law* accessed online at:  
<https://bradfordwestgwillimbury.civicweb.net/filepro/documents/562/?preview=82056>
- 2016 *The Corporation of the Town of Bradford West Gwillimbury By-law 2016-65. Swimming Pool Fence By-law* accessed online at:  
<https://bradfordwestgwillimbury.civicweb.net/filepro/documents/?preview=72907>
- 2013 *The Corporation of the Town of Bradford West Gwillimbury By-law 2013-06. Division Fence By-law* accessed online at:  
<https://bradfordwestgwillimbury.civicweb.net/filepro/documents/?preview=138748>
- 2011 *The Corporation of the Town of Bradford West Gwillimbury By-law 2011-23. Sign By-law* accessed online at:  
<https://bradfordwestgwillimbury.civicweb.net/filepro/documents/?preview=580>
- 2012 *The Corporation of the Town of Bradford West Gwillimbury By-law 2012-025. Clean Yards By-law* accessed online at:  
<https://bradfordwestgwillimbury.civicweb.net/filepro/documents/?preview=8263>
- 2008 *The Corporation of the Town of Bradford West Gwillimbury By-law 2008-014. Fortification of Land By-law* accessed online at:  
<https://bradfordwestgwillimbury.civicweb.net/filepro/documents/?preview=8273>
- 1998 *The Corporation of the Town of Bradford West Gwillimbury By-law 98-65. Property Standards By-law* accessed online at:  
<https://bradfordwestgwillimbury.civicweb.net/filepro/documents/?preview=578>

**Appendix A: District Properties – Statement of Contribution**

*See separate Document*

**Appendix B: Policy Review and Implementation**

*See Separate Document*

**Appendix C: Consultation Summary**

*See Separate Document*