

AIR RELEASE CHAMBER PLAN

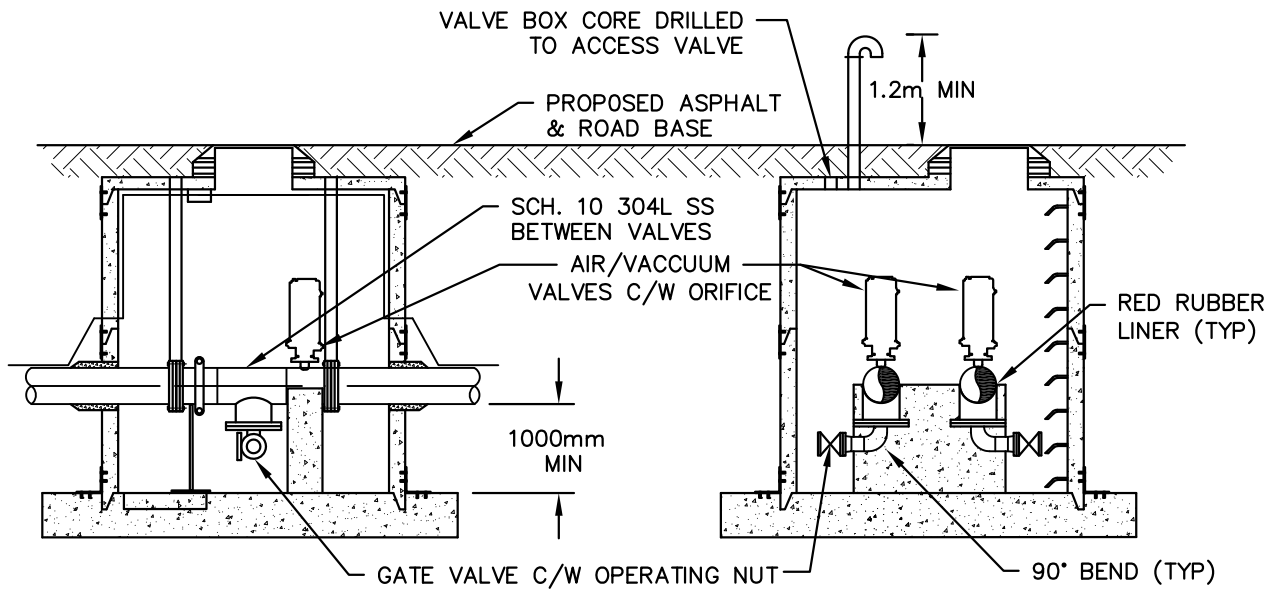

AIR RELEASE CHAMBER SECTION "A"

AIR RELEASE CHAMBER SECTION "B"

NOTES:

1. SEE BWG DESIGN STANDARD E104 GENERAL SANITARY CHAMBER DETAILS FOR COMMON CHAMBER ELEMENTS.
2. PROVIDE AIR RELEASE TO SURFACE BY STACK OR AS DIRECTED BY ENGINEERING.
3. ODOR CONTROL TO BE PROVIDED AS DIRECTED BY ENGINEERING.

TOWN OF BRADFORD WEST GWILLIMBURY

TYPICAL SANITARY AIR RELEASE CHAMBER DETAILS

SCALE: N.T.S.
 LAST REVISED: JULY 2014
 STD.DWG.

E106